

Revision B
Updated 2010

ELSTON MANUFACTURING GA-400 OWNERS MANUAL

Table of Contents

1 Safety Information.....	1
2 General Information.....	2
3 Assembly Instructions.....	3
4 Using Your Gopher Getter.....	6
Initial Setup.....	6
Operating Instructions.....	7
5 Maintenance.....	9
6 Parts List.....	1-1

1 Safety Information

Operating this gopher getter safely is essentially no different from operating a tractor safely. If you are the least bit unsure of your ability to safely operate a tractor with an implement, find someone you respect with experience to show you how to operate a tractor safely. Don't depend on this paper to tell you how to do it.

In all probability, you have operated a tractor much more than I, so I won't insult your intelligence with a bunch of obvious warnings. That said, I want to leave you with a couple of things I believe are worth repeating.

Operating for years without an accident is not the same as safety. - It is possible to do something unsafe for years and not be hurt. This does not mean it is alright to continue this unsafe behavior; it just means you have been lucky. For example, I remember a farmer who never had a serious accident and who wasn't wearing his safety belt (that day at least). He rolls his tractor while moving round bales out of a ditch and he ends up underneath the tractor. Thankfully, in this case, he was only hurt, not killed, thanks to the good hearing of a neighbor who heard his calls for help. I hope we can agree that isn't operating safely. I can think of other stories of farm injuries with a similar theme and I expect you can as well. Please take the time to consider all those little things you do before your luck runs out.

Don't take short cuts with safety when you are in a hurry. - This is certainly one of the areas where hindsight is 20/20. I'll admit I've done it before and I expect most of you have too. If I may be blunt for a moment, DON'T take shortcuts.

Be safe.

2 General Information

Thank you for purchasing a Gopher Getter from Elston Manufacturing. We are confident this product will provide you with years of service.

This gopher getter works by creating an artificial tunnel. The poison is dropped into the tunnel where the gophers find it and die underground out of reach of other animals. The depth of the tunnel is adjustable to better match the depth that the gophers are digging in your area.

The gopher getter will apply approximately one pound per acre of Elston gopher getter bait when the burrows are spaced 20 feet apart. When used with rolled oats and the seeder slide with the larger 7/8" opening, the application rate will also be slightly less than one pound per acre.

We always welcome feedback on our products. If you have comments, suggestions, or problems with the unit please contact us.

3 Assembly Instructions

Before beginning assembly, verify that all parts were shipped with the gopher getter. The Gopher Getter is shipped from the factory in the four pieces shown below.



Illustration 1: Parts of GA-400 as Shipped

Inside the bait box you will find a parts kit that includes the following parts.

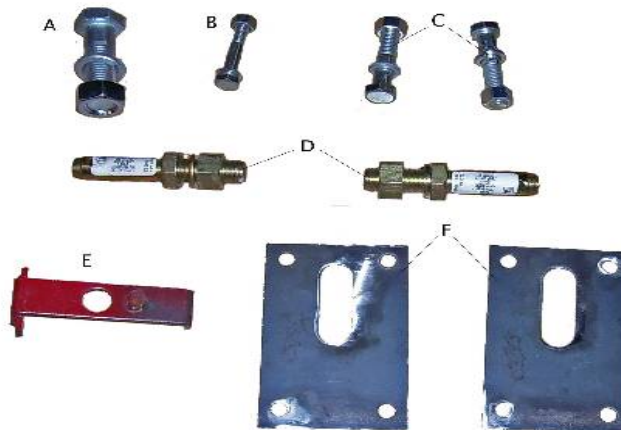

Illustration 2: Parts Kit

Label	Description
A	1" UNC 3 1/2" Hex Head Bolt w/ nut and lock washer
B	1/2" UNC 3" Hex Head Bolt (Grade 2) w/ nut and lock washer
C	5/8" UNC 3 1/2" Hex Head Bolt w/ nut and lock washer
D	G5-255 Category 1 Lower Link Pin
E	G4-208A Seeder Slide 7/8" Hole
F	G4-286 Lower Poison Guide Plate

Table 1: Contents of Parts Kit

Assembly of the GA400 is very straightforward and requires the installation of only seven bolts. If after reading the assembly steps below, you have any questions please refer to the parts list in the back of this manual. It presents much of the information below in a more visual way you may find easier to understand.

1) Attach the seeder/knife assembly to the frame assembly using the two bolts labeled A and B. Do not over tighten these two bolts. The smaller bolt is designed to shear when the knife hits an underground obstruction before damage occurs to the gopher getter. When this bolt shears, the large bolt must be loose enough to allow the knife and the parts attached to it to pivot. Once assembled it will look like the illustration below. If the legs



Illustration 3: Frame and Seeder/Knife Assembly Mounted Together
on frame are pivoted down the unit will support itself.

2) Attach the lift arm tripod to the frame using the two hitch pin bolts and the ½” bolt already attached to the frame. Note that the lock washers for the hitch pins go inside the frame.



Illustration 4: Lift Arm Tripod as Installed

3) Attach the coultter assembly to the frame. The coultter shank is already attached to the frame and should be positioned so the shaft on the shank is closest to the front of the frame. Before bolting the coultter assembly to the frame, attach the coultter assembly to the coultter shank using the coultter clamp to hold it in place.

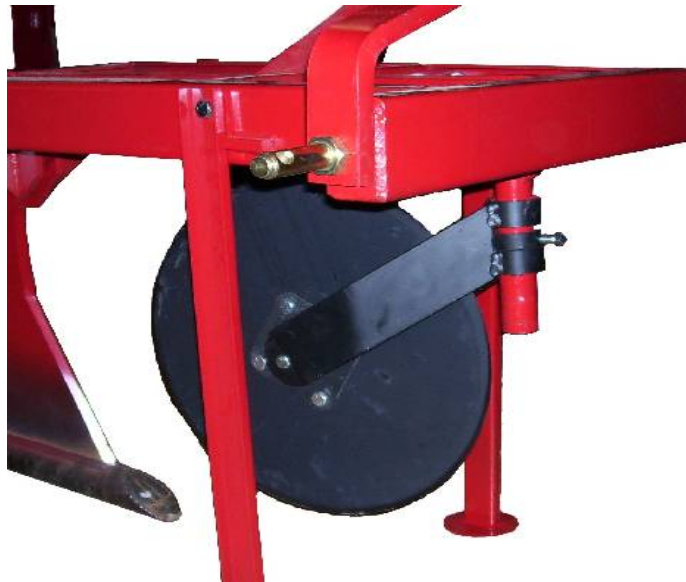

Illustration 5: Coultter Assembly as Installed

4 Using Your Gopher Getter

Initial Setup

You have 4 primary adjustments with this machine: the depth of the torpedo tube, the depth of cut of the coulter, the angle of the torpedo tube, and the setup of the bait box.

Depth of Torpedo Tube:

The depth of the torpedo tube should be set so the gopher getter makes a tunnel at the depth that gophers tunnel in your area. As gopher dig at a range of depths even in the same area, aim to set the gopher getter to the average depth. It is not necessary to be exact.

To set the depth of the torpedo tube:

- 1) Loosen and remove the bolts attaching the rear (packer) wheels to the gopher getter knife assembly.
- 2) Move the packer wheels up or down to achieve the desired depth and remove the bolt. Using the top bolt will set the torpedo tube to a depth of approximately 10” and the bottom bolt to approximately 6”. The exact depth will depend on the angle of the torpedo tube.

Depth of Coulter Blade

The best depth is just deep enough to do the job. If it is too deep, it will be more difficult to get the gopher getter into the ground. If it is too shallow, roots will catch on the knife and tear up the ground. In sod or pasture, set the coulter just deep enough to cut the upper layer of roots, approximately 4 or 5 inches. When operating in alfalfa, set the coulter deeper. Either set the coulter so the bottom edge is just above the center of the torpedo tube or set it so the flange for the coulter hub runs just above the surface of the soil. However if you have stronger soil or an older alfalfa field you may be able to set the coulter a bit shallower.

The depth of the coulter can be set by loosening the set screw on the coulter clamp and moving the coulter up or down as necessary. Make sure the coulter will not hit the frame as it runs through the soil and the hub of the coulter will not run through the dirt.

Angle of Torpedo Tube

Adjusting the length of the upper arm of the 3-point hitch on your tractor will control the angle of the torpedo tube. The torpedo tube should be sloping slightly downward at the operating depth. The exact angle will depend on your soil type and moisture levels but a downward slope of couple degrees is typically best. If the angle is too steep, the gopher getter will disturb more soil. In addition, at larger angles, the gopher getter fails to effectively get to depth so the packer wheel will turn and bait will drop. As the torpedo

tube gets close to level, soil may plug up the torpedo tube and prevent any poison from dropping

Setup of Bait Box

Your gopher getter is already setup for use with Elston gopher bait (milo w/0.5% strychnine). If you are using other types of poison such as oats or cracked corn or products with a lower amount of effective ingredients, you will need to replace the factory seeder slide with a seeder slide with a larger (7/8") opening (Part # G4-208A). One of these can be found in the parts package.

Operating Instructions

Important: The advice and tips in this manual are general since they must work for gopher getter users throughout the country. For information specific to your area please speak with the dealer that you purchased the unit from, your local extension agent, or area farmers that use gopher getters.

This machine works best in moist soil. It is rarely a problem, but if the soil is too wet, it will stick to the knife and the packer wheels and interfere with the depth setting of the gopher getter. A more common problem is soil that is too dry. When it is, the machine will be very hard to get into the ground and it will refill the tunnel (see a couple paragraphs below for tips in this condition). Depending on your soil type, you may find the gopher getter works in a huge range of soil moisture conditions or that it works well in a fairly narrow range of conditions.

The bait that you apply with the gopher getter will be most effective if applied when gophers are active but high quality food is scarce. Spring and fall are the most effective times especially spring. When you use any type of gopher bait during the summer, expect reduced control results.

Space your burrows 20 to 30 feet apart in areas active with gophers or bordering areas with high population of gophers that are not treatable (like a neighbors CRP). To limit damage from erosion, avoid making burrows straight down the slope of the hill. The gopher getter will apply approximately one pound per acre of Elston gopher getter bait when the burrows are spaced 20 to 25 feet apart. When used with rolled oats and the seeder slide with the larger 7/8" opening, the application rate will also be approximately 1 lb/acre. When measured over a whole field your application rate will be less since it is not necessary to cover the whole field.

If you have certain types of soil or low soil moisture, the gopher getting may have trouble getting to full depth (where the packer wheel will turn consistently). First try adjusting the angle of the frame by changing the length of the upper arm on the three point.

Typically, it works best when the torpedo tube is sloping slightly downward into the soil (a few degrees). If this doesn't fix the problem, you may add weight to the unit, up to 500 pounds. Feel free to build a tray or add other pieces to the unit to help hold and secure that weight.

Operating Tips

- Never turn or back up with the machine in the ground. This will damage the unit.
- Never over tighten the one inch bolt attaching the knife to the frame. The large bolt must be loose enough to allow the knife and the parts attached to it to pivot when the shear bolt fails.
- Never over grease the seeder slide. Too much grease will cause bait to build up on the interior surfaces of the unit when it contacts the bait traveling through the opening in the seeder slide and cause it to plug.
- Always replace the shear bolt with an identical grade 2 bolt. A higher grade bolt like a grade 5 will greatly increase the risk of expensive damage to the frame when you hit a large obstruction.
- Always check that there are no underground pipe or other lines in the area you will be working. There is nothing worse to hit with your gopher getter. (Yes, It's happened.)
- Always start slow especially if you're new to the gopher getter or operating in an unfamiliar field. At no point should you go faster than 5 mph. In most conditions, especially hard or rocky ground, it will be necessary to limit your speed further.
- Always stop quickly when the shear bolt fails. If you are moving quickly and/or the obstruction that you hit is especially tenacious like a tree root or an oddly shaped rock, the tip can catch long enough for the bait box to pivot around and damage itself on the frame.

5 Maintenance

Every use:

Inspect torpedo tube/point for excessive wear or damage

Inspect shear bolt for damage, replace if necessary

Every season or 200 lbs of bait:

Check if the unit needs to be greased. If so, lightly grease the unit at the grease points on the seeder casting and packer wheel axle remembering to be careful not to over grease the seeder casting

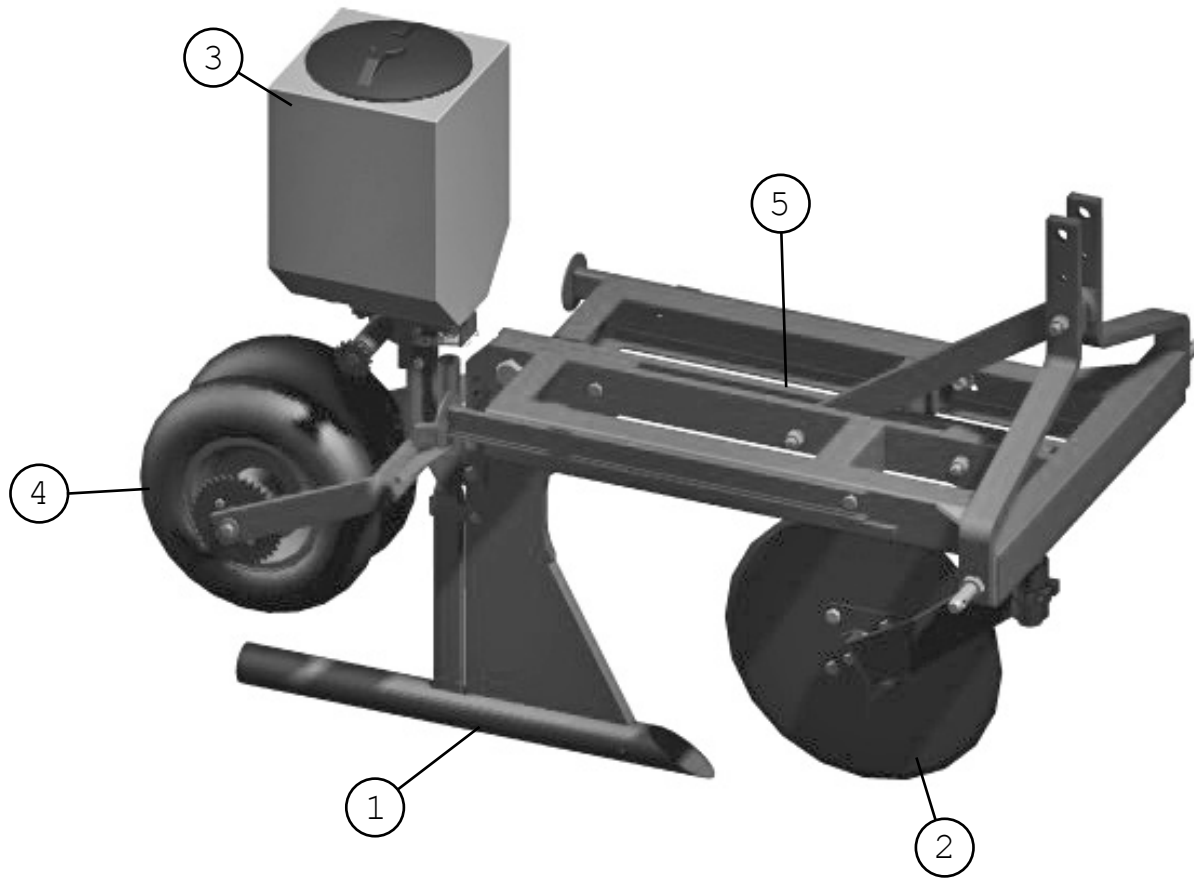

Assemblies

Common Parts

Ref #	Name	Page #	Name	Part #	Page #
1	Knife Assembly	1-2	Torpedo Point	G1-105	1-2
2	Coulter Assembly	1-3	Coulter Blade - 18"	G2-370	1-3
3	Seeder Assembly	1-4	Tire	G3-125	1-5
4	Packer Wheel Assembly	1-5	Tripper	G4-269	1-4
5	Frame Assembly	1-6	Knife Assembly (Complete)	G1-100	1-2

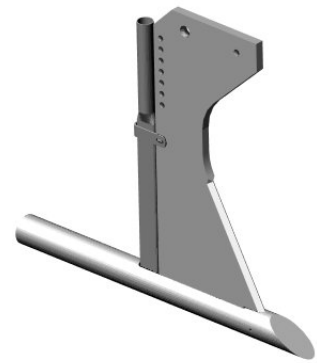
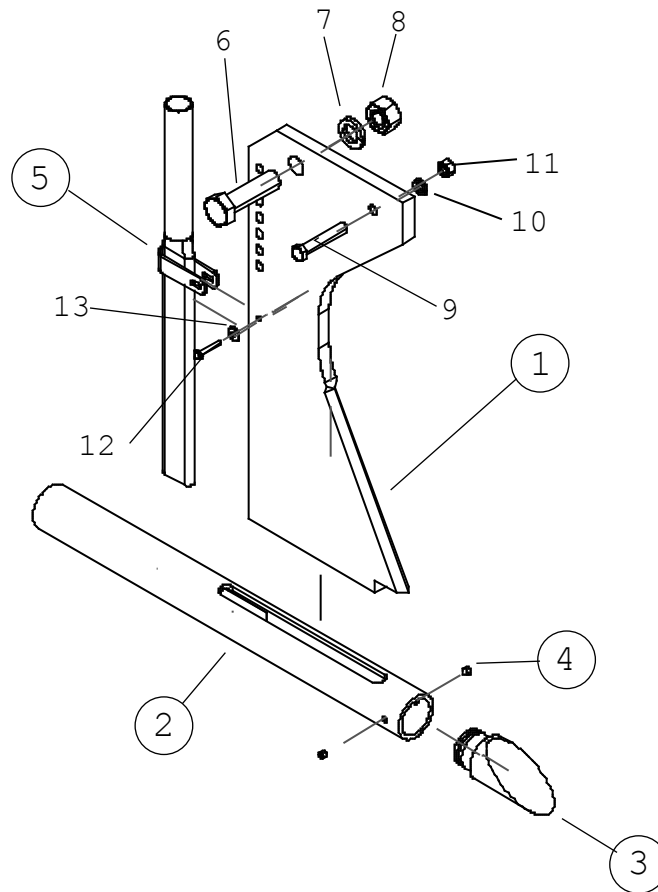

Ref #	Name	Part #	Ref #	Description
1	Knife	G1-103	6	1" x 3 1/2" Hex Head Bolt
2	Torpedo Tube	G1-104	7	1" Lock Washer
3	Torpedo Point	G1-105	8	1" Hex Nut
4	3/8" x 3/8" Set Screw	G1-143	9	1/2" x 3" Hex Head Bolt (Grade 2)*
5	Seeder Tube	G1-193	10	1/2" Lock Washer
1-5, 12-15	Knife Assembly (complete)	G1-100	11	1/2" Hex Nut
			12	1/4" x 1 1/2" Hex Head Bolt
			13	1/4" Flat Washer (One Not Shown)
			14	1/4" Lock Washer (Not Shown)
			15	1/4" Hex Nut (Not Shown)

* This bolt must be grade 2 (or softer). It is designed as a shear bolt to prevent damage when hitting underground obstructions. Using a harder bolt could result in expensive repairs.

All hardware listed is coarse thread (UNC) and Grade 5 or better unless otherwise noted.

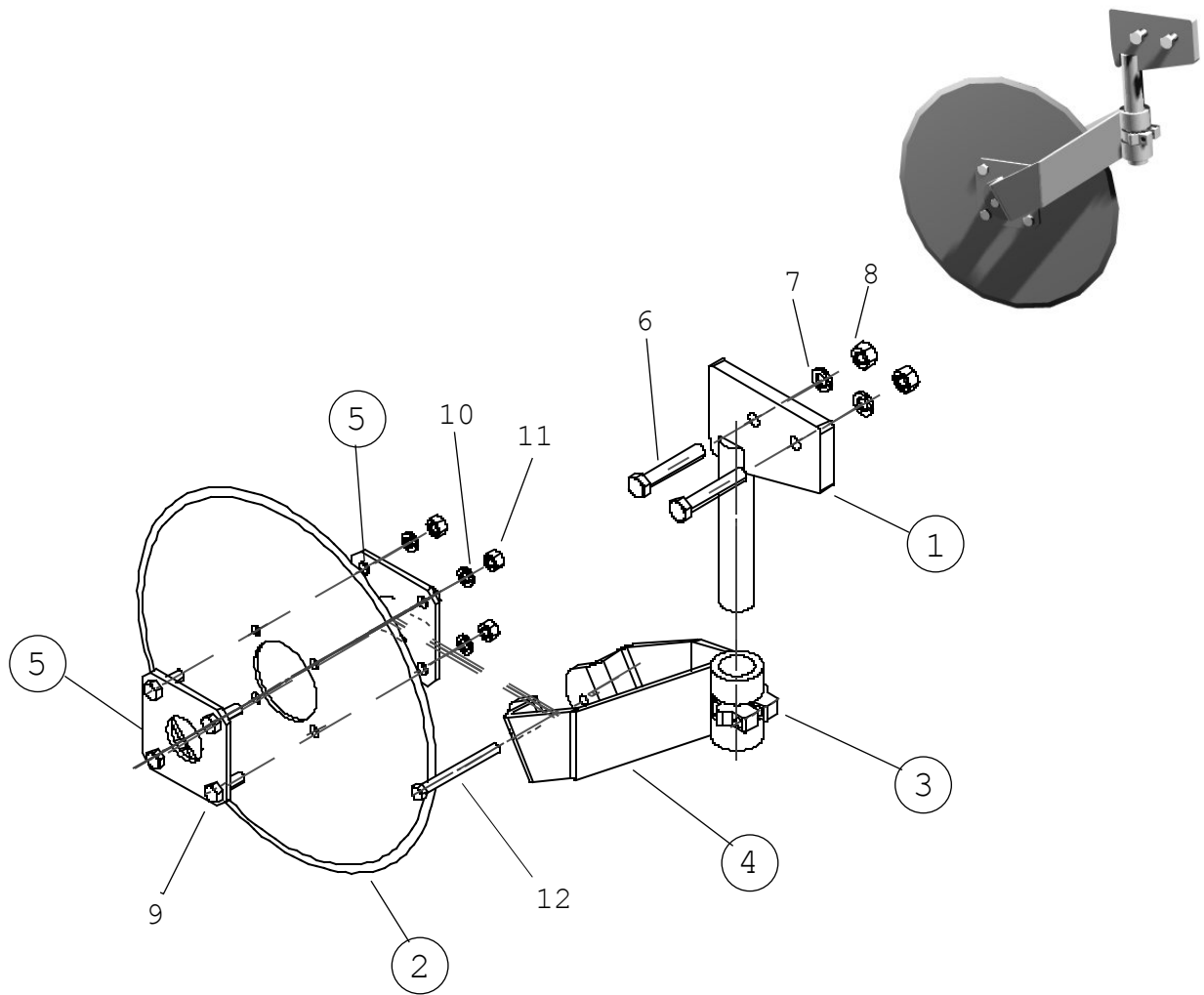

Ref #	Name	Part #	Ref #	Description
1	Coulter Shank	G8-201	6	5/8" x 2 1/2" Hex Head Bolt
2	Coulter Blade - 18"	G2-370-18	7	5/8" Lock Washer
	Coulter Blade - 20"	G2-370-20	8	5/8" Hex Nut
	Coulter Blade - 22"	G2-370-22	9	1/2" x 1 1/2" Hex Head Bolt
3	Coulter Clamp	G2-375	10	1/2" Lock Washer
4	Coulter Side - 18"	G2-380-18	11	1/2" Hex Nut
	Coulter Side - 20"	G2-380-22	12	7/16"-20 4 1/2" Hex Head Bolt
	Coulter Side - 22"	G2-380-22	13	7/16" Lock Washer (Not Shown)
5	Coulter Blade Hub	see p. 3-1	14	7/16" Hex Nut (Not Shown)
5,9-14	Coulter Hub Assembly	G2-379		
2,5,9-14	Coulter Blade and Hub Assembly	18" G2-390-18 20" G2-390-20 22" G2-390-22		
2-5,9-14	Coulter Assembly	18" G2-100-18 20" G2-100-20 22" G2-100-22		

All hardware listed is coarse thread (UNC) and Grade 5 or better unless otherwise noted.

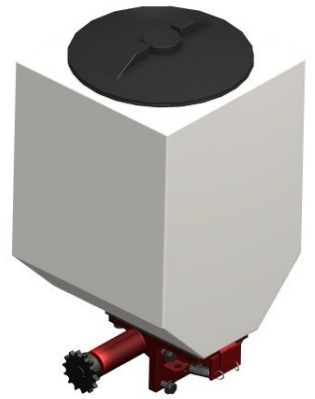
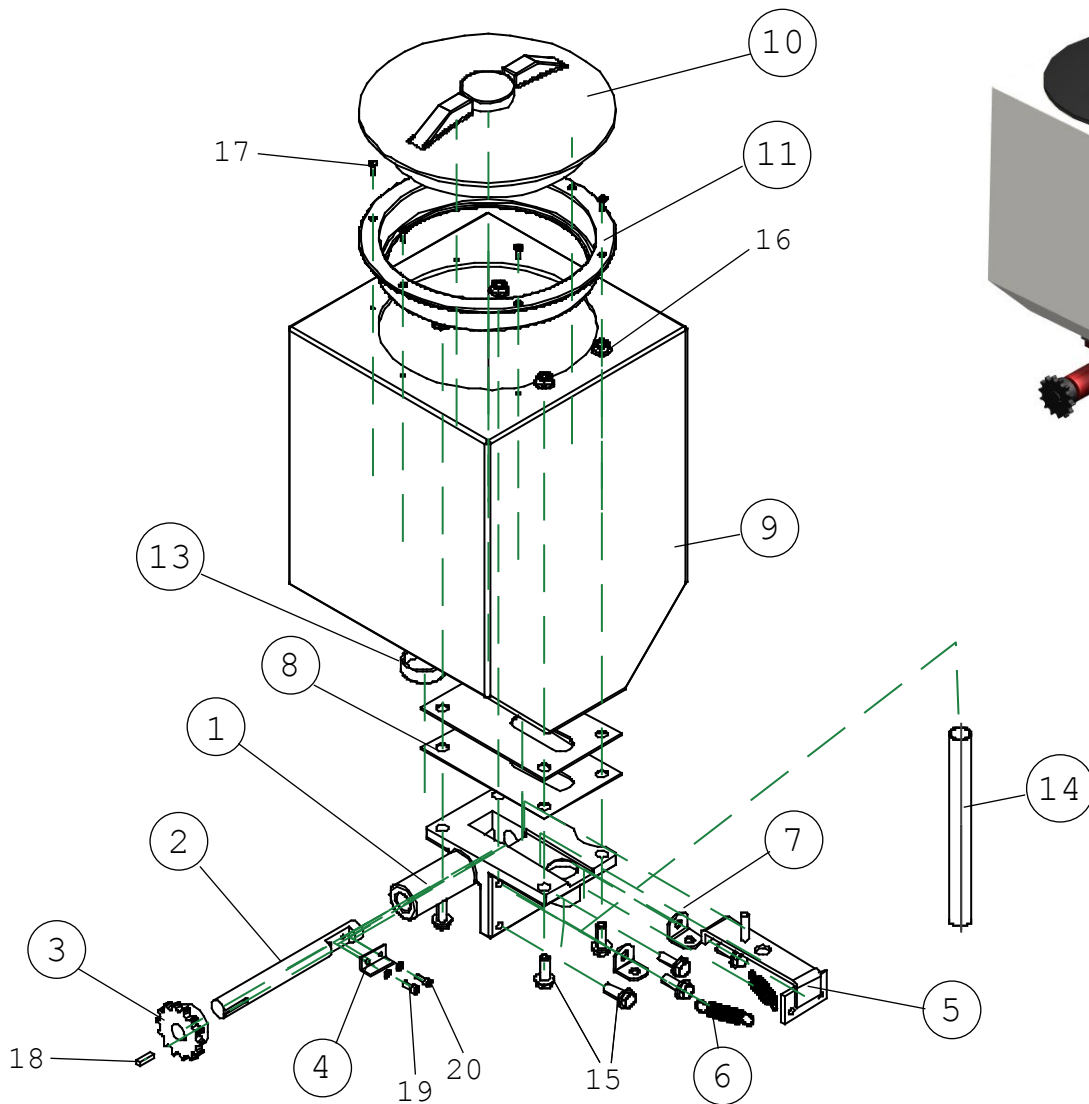

Ref #	Name	Part #	Ref #	Name	Part #
1	Seeder Casting	G4-200	13	Drain Cap	G4-221P
2	Seeder Axle	G4-201	14	Plastic Hose	G4-122
3	Drive Gear	G4-203	9-13,17	Seeder Box Assembly	G4-235P
4	Tripper	G4-269	1-20	Seeder Assembly	G4-100P
5	Seeder Slide - 5/8" Hole for 7/8" Hole use G4-208A	G4-208			
6	Seeder Slide Spring	G4-215			
7	Spring Holder Clip	G4-278			
8	Guide Plate - Long Slot Short Slot	G4-286 G4-286A			
9	Seeder Box	G4-230P			
10	Seeder Box Lid	G4-234P			
12	Lid Retaining Strap (Not Shown)	G4-233P			
10-12	Seeder Box Lid Assembly	G4-231P			
			Ref #	Description	
			15	3/8"-16 x 1" Wislock Hex Bolt	
			16	3/8"-16 Wislock Hex Nut	
			17	#8 1/2" Sheet Metal Screw	
			18	9/16" of 3/16" Square Key Stock	
			19	#10 Internal Locking Washer	
			20	#10-24 1/2" Allen Screw (Use LocTite)	

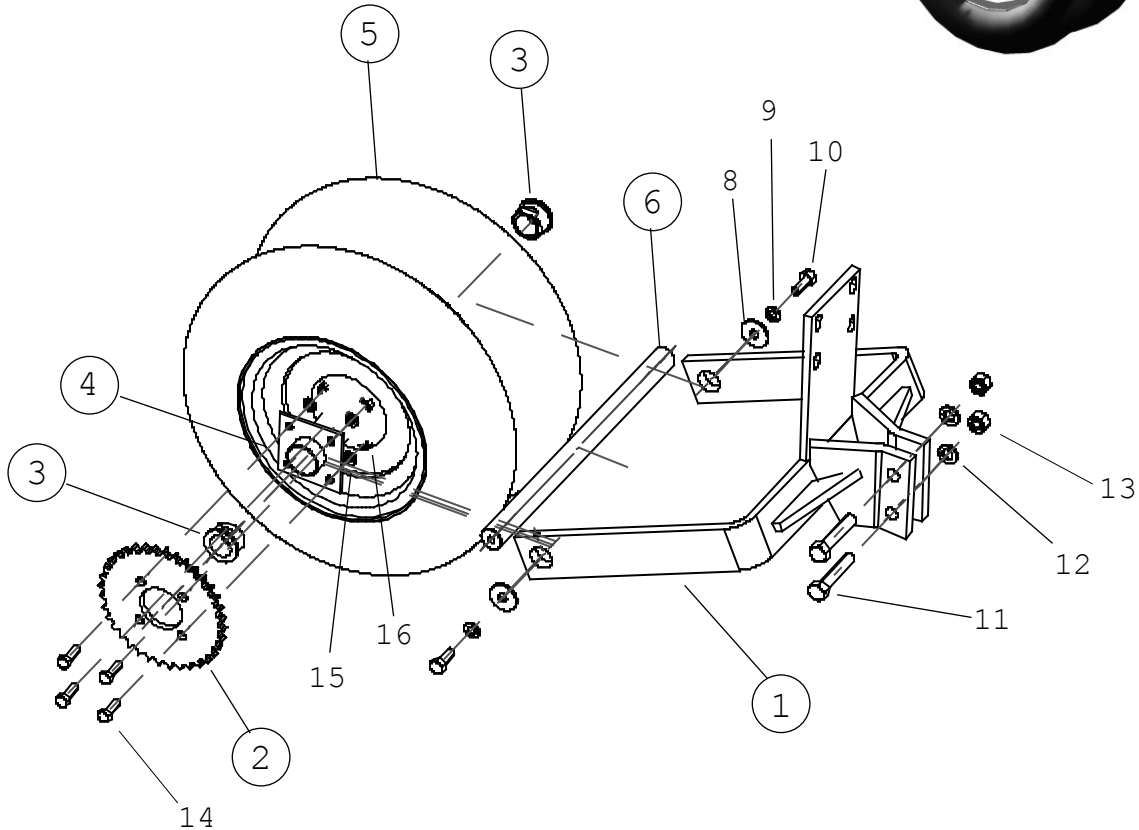
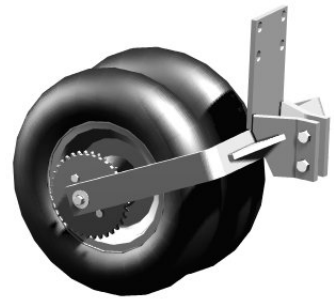

Ref #	Name	Part #	Ref #	Description
1	Packer Wheel Bracket	G3-292	8	3/8" x 1 3/4" Fender Washer
2	Large Sprocket	G3-283	9	3/8" Lock Washer
3	Axle Bushing	G3-324	10	3/8"-16 x 1" Hex Head Bolt
4	Packer Wheel Base	N/A*	11	1/2" x 2 1/2" Hex Head Bolt
5	Packer Wheel Tire	G3-125	12	1/2" Lock Washer
6	Packer Wheel Inner Axle	G3-177	13	1/2" Hex Nut
7	Chain (Not Shown)	G3-321	14	5/16" x 1" Hex Head Bolt
3,4,5	Packer Wheels w/Tires	G3-120	15	5/16" Lock Washer
3,4	Packer Wheels No Tires	G3-121	16	5/16" Hex Nut
1-10, 14-16	Packer Wheel Assembly	G3-100		

All hardware listed is coarse thread (UNC) and Grade 5 or better unless otherwise noted.

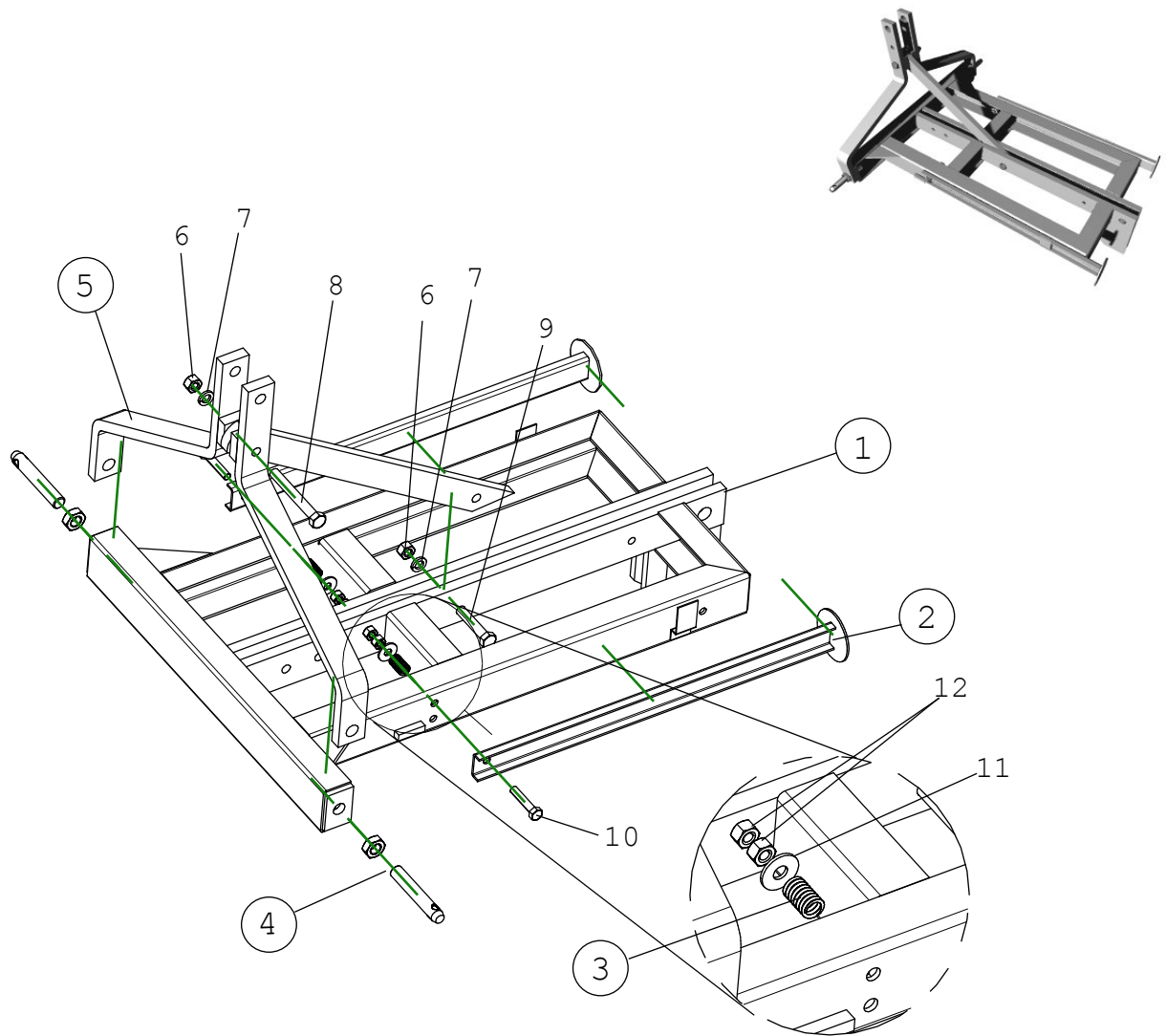

Ref #	Name	Part #	Ref #	Description
1	Frame	Call	6	5/8" Hex Bolt
2	Leg	G5-254	7	5/8" Lock Washer
3	Leg Spring	G5-257	8	5/8" x 5" Hex Head Bolt
4	Cat 1 Lower Link Pin	G5-255	9	5/8" x 3 1/4" Hex Head Bolt
5	3-Point Hitch Assembly	G5-271	10	1/2" x 2 1/2" Hex Head Bolt
			11	1/2" Flat Washer
			12	1/2" Hex Nut

Blade Hub

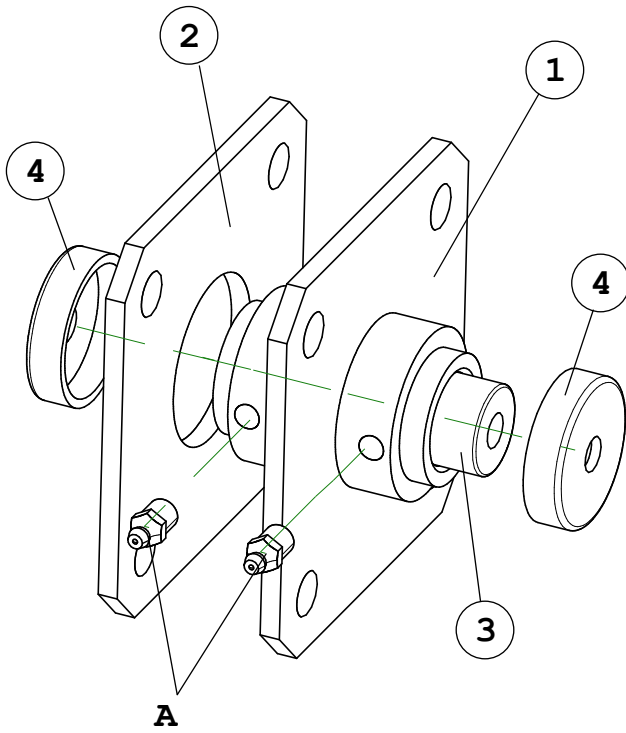

Label	Name	Part #
1	Blade Flange w/ Hub	G2-381
2	Blade Flange	G2-382
3	Inner Bearing	G2-383
4	Bearing Cap	G2-384
A	1/4"-28 SAE-LT Grease Fitting	N/A*

*Not Available Separately

LIMITED WARRANTY TERMS

Elston Manufacturing, Inc. offers a one (1) year, non-transferable, Limited Warranty against specified defects as set forth below for Elston Manufacturing, Inc. product lines from the date of purchase through proof of purchase by providing original receipt.

This Limited Warranty specifically excludes normal wear and tear of products and is provided solely under the conditions that the product has been properly installed, operated and maintained in accordance with all applicable instructions. Proper installation instructions, or operating manuals, are provided with each product and operating condition. Travel, diagnostic cost, labor, transportation and any and all such costs related to repairing a defective product will be the responsibility of the owner. This warranty is extended only to the original owner of any equipment, the end user.

Elston Manufacturing, Inc.'s sole obligation under this Limited Warranty is to, in its sole and absolute discretion, either repair, modify, or replace (i.e. correct), Elston Manufacturing, Inc.'s products subject to this Limited Warranty. The allegedly defective products must be returned to Elston Manufacturing Inc. or an authorized service center freight paid by buyer. After confirmation by Elston Manufacturing, Inc. that a defect does exist in the product that is covered under this Limited Warranty then Elston Manufacturing, Inc. shall, in its sole and absolute discretion, either repair, modify or replace the product(s) and return the product(s) to the owner freight paid by Elston Manufacturing, Inc.

Elston Manufacturing, Inc. products received by Elston Manufacturing, Inc. within one (1) year from the original sale date to customer and found to be defective as referenced above will be corrected as referenced in the previous paragraph at no charge for parts (provided by original factory) or labor but will include freight paid by buyer. Failure to use original factory parts voids this warranty. Elston Manufacturing, Inc. products received by Elston Manufacturing, Inc. after one (1) year from original shipment date to customer will be corrected as foresaid for a charge of the then-current sale price of parts and labor with freight paid by buyer. Exception: Any parts to be found defective at any time that come under a recall status from providing manufacturer, will be covered under the terms and conditions of the recall status provided by manufacturer.

THIS LIMITED WARRANTY BY ELSTON MANUFACTURING, INC. IS IN LIEU OF ANY AND ALL OTHER WARRANTIES, EXPRESSED OR IMPLIED, INCLUDING WITHOUT LIMITATION TOTHE IMPLIED WARRANTIES OF MERCHANTABILITY AND FITNESS FOR A PARTICULAR PURPOSE. NO ONE IS AUTHORIZED BY ELSTON MANUFACTURING, INC. TO EXTEND OR ALTER THE TERMS OF THIS LIMITED WARRANTY. ELSTON MANUFACTURING, INC. ASSUMES NO LIABILITY FOR LOSS OF USE OR ANY DIRECT, INDIRECT, INCIDENTAL, SPECIAL, CONSEQUENTIAL OR OTHER DAMAGES OF ANY KIND IN RESPECT TO THE USE OF THE ELSTON MANUFACTURING, INC EQUIPMENT.

Accessory items furnished by Elston Manufacturing, Inc. are covered by a Limited Warranty for a period of one (1) year from date of original sale, subject to the conditions, limitations, and disclaimers stated above, for replacement of defective materials, provided such items are returned freight paid by buyer to Elston Manufacturing, Inc. and are determined by Elston Manufacturing, Inc. to be defective in its sole and absolute discretion.

This Limited Warranty shall not apply to any piece of equipment, parts or accessories repaired by anyone other than Elston Manufacturing, Inc. personnel, or its authorized service organizations.



ELSTON MANUFACTURING INC.
706 N Weber
Sioux Falls, SD 57103
www.elstonmfg.com 1-800-845-1385