

Elston Manufacturing HC Heater Owners Manual

Table of Contents

Important Safety Information.....	ii
1) Description of Heater.....	1
General information about your heater including specifications	
2) Operation Instructions.....	2
Basic instructions for using your heater	
3) Service Instructions.....	6
Recommendations on maintaining your heater	
4) Troubleshooting Guide.....	7
Detailed guide to help you diagnose and fix problems fast	
5) Installation Instructions.....	11
How to install and setup the HC heater.	
Parts List.....	A1
Wiring Diagrams.....	B1
HC-550 Installation Instructions.....	C1

Valid for models beginning with Serial # 4301

Safety Information

The heater you have purchased was designed, first of all, to be safe. However, since this heater burns propane, safety precautions are necessary for the safe and reliable operation of this product. For your safety, please take the time to read the appropriate sections of this manual before installing, servicing, or operating the heater.

⚠ WARNING Use only propane vapor for fuel. Use this heater only with regulators and tanks that provide propane vapor at 10.5 to 11 inches of water column. Use of a different fuel, a liquid withdrawal cylinder, and/or propane vapor at a significantly different pressure risks fire or explosion.

Use a carbon monoxide detector

A damaged heater could leak carbon monoxide into the heated area. As with your home, it is strongly recommended that you use a carbon monoxide detector whenever people are regularly in the space heated by this heater.

Use only exact parts or manufacturer approved replacements for repair
For proper function and safety, critical parts such as hoses, regulators, guards, and controls, must match the existing part.

⚠ CAUTION Do not service heater until unit has cooled for at least 10 minutes
Heat exchanger and attached parts remain hot enough to cause burns after unit is shut off until they have cooled for a few minutes.
Turn off power to the heater during service. Keep power off unless necessary for testing as heater can start unexpectedly and could pinch or cut fingers or sustain damage from tools.

NOTICE Use only in accordance with local regulations. Current regulations in your area may require that the installer of this heater or, more likely, that the person servicing the propane fuel system meet certain requirements. If you are unsure what is required, please refer to the current regulations in your area or speak with the authority having jurisdiction before beginning installation.

WARNING: During operation, the exhaust of this heater produces carbon monoxide, a chemical known to the state of California to cause birth defects and/or other reproductive harm.

As always, apply common sense and beware the perils of ignorance. If you're not sure it's safe or don't have enough knowledge to know if it is safe, then don't do it.

Description of Heater

The HC heater you have purchased is a thermostatically controlled propane heater. It is designed to be mounted on the inside of the cab on heavy equipment or inside a small building.

It is a heavy duty forced air heater with electronic ignition. To maximize safety, the combustion air is completely separate from the inside air. The combustion air is drawn from outside, burnt with propane, heat is pulled from it to warm the inside air, and the exhaust exits outside.

Specifications

Dimensions.....	16 in wide x 11.5 in tall x 8 in deep
Weight.....	27 lbs
Shipping Weight.....	32 lbs
Rating.....	20,000 BTU
Combustion Air Inlet Diameter.....	2 in
Exhaust Outlet.....	1.5 in steel pipe
Hot Air Outlet Diameter.....	6 in
Rated Voltage.....	12 V
Operating Voltage Range (with heater running).....	11.5-13.5 V
Average Current Draw.....	3 amps
Fuel Requirement.....	propane (LP gas)
Fuel Consumption.....	0.8 lbs/hr max

Operating Instructions

Please read the safety information on page 2 if you haven't already done so.

These instructions assume the heater has already been installed. For installation instruction please go to chapter 5 (page 11).

Operating Precautions

This heater is designed to heat the occupied areas of vehicles and heavy equipment and provide freeze protection of cargo in trailers and truck bodies. It should not be used for heating buildings or recreational vehicles.

⚠ WARNING To prevent fire or explosions, keep solid combustibles, such as paper or cardboard, a safe distance away from the heater. Do not store explosives, flammable liquids, or flammable gases in the heated area unless the propane tanks have been removed and the power to the heater turned off and locked out.

⚠ WARNING Carbon monoxide could be produced by a damaged heater. Symptoms of carbon monoxide include headache, dizziness, burning eyes and nose, nausea, and dry mouth or sore throat. If you experience these symptoms, immediately seek fresh air and seek medical attention. Ventilate the area to reduce the carbon monoxide to safe levels before reentering.

⚠ WARNING Never enter the heated area after the heater has set unattended for extended period of time with the gas on while operating a device like a phone, cigarette, or forklift that could be a source of ignition. If a leak developed, you may not detect the odorant in the propane soon enough to extinguish the source of ignition and prevent it from igniting the mixture.

If you smell propane or suspect flammable vapours may be present (from a spilled flammable liquid, etc.) when entering, take immediate action. Follow your company's procedure if one is established. Otherwise:

- Do not do anything that could ignite the mixture including operating an electrical switch, disconnecting an extension cord, or using your phone. Do not light matches or any other source of flame.
- Get everyone away from the area immediately.
- Call your fuel supplier and/or the fire department
- Do not reenter the area until the trailer has been aired out and declared safe.

- Have a properly trained service person repair any leaks and bring the heater back into service.

NOTICE Do not disconnect power from the running heater except in an emergency. Stopping the heater before it has finished its cooldown cycle will cause it to wear out significantly faster. Wait to use the switch on the side of the heater until the fans have stopped. Please turn down the thermostat or use the switch on the remote box to turn off the unit during normal operation.

Propane has a chemical added to give it a distinctive odor. If you are not familiar with that odor, please contact your local LP supplier. They can provide you with a scratch and sniff pamphlet. Use extra caution if you smoke or strong odors are present as this can make the odor difficult to notice. Like most other odors, extended exposure can reduce your sensitivity to the smell. Since LP gas is heavier than air, please remember that the odor will be stronger at lower levels.

Before Running the Heater the First Time

Please take a moment to familiarize yourself with your heater. The cover to the heater is attached with four bolts as shown in Illustration 1 below.

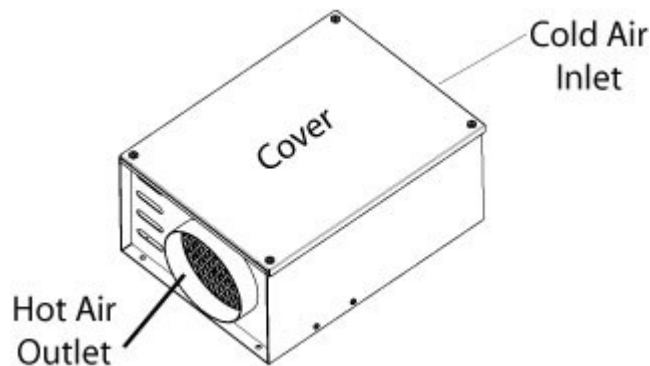

Illustration 1: Overall View of Heater

The combustion air enters in an opening on the bottom of the lower left of the heater. It is combined with propane and burnt in the burner, travels through the heat exchanger, and exits outside through the combustion air outlet on the bottom heater. The inside air is blown over the heater exchanger by the fan, where it captures the heat produced by the burning propane.

Near the heater, you will see a thermostat. Please consult the manual that came with the thermostat for instruction on how to operate it.

A switch, a green indicator light, and a red indicator light are located on the side of the heater where the gas and the power enter the heater. The switch operates as a emergency off switch; it disconnects all power to the heater. It should be used when the heater is not needed for an extended period of time and should not be used for shutting off the heater when it is running or for day to day operation. For day to day operation, the thermostat should be used instead since it will allow the heater to safely cool down. The green indicator lights is on when there is power to the heater and the internal circuit breaker has not tripped. The red indicator light is on when the safety system has checked out but the heater is either waiting to light or unable to light.

Normal Operation for Heater

When the switch on the heater is off, the propane turned on, and the thermostat set to its minimum setting, no lights will be on or fans will be running. When the switch is turned on the green indicator light will come on. If the thermostat is turned up until the heater starts (this will be unnecessary below 20 F), the blower and fan will start and after a short delay the red indicator light will come on. After a 15 to 30 second delay, the gas turns on, the red light turns off, and a faint clicking noise will be heard as the spark module sends a high voltage spark to the spark probe. The heater will attempt to light for approximately 10 seconds. If the heater lights, the red light will turn off. If not, the red light will turn back on and the heater will wait 15 to 30 seconds to try again.

The heater will run until the trailer reaches the temperature set on the thermostat. The gas will turn off but the blower will run for an additional 2 to 3 minutes to cool down the heater.

Running the Heater For the First Time or After the Unit Has Been Sitting a Long Time

Whenever you need to verify that the heater is working properly, please follow the four steps below.

1) Check the air inlets and outlets

Check that the air inlets and outlets are undamaged and unblocked, especially the ones that are outside.

2) Check the fuel system

Check that the propane tank is securely mounted and the gas lines and fittings between the propane tank and the heater are tight and undamaged. Turn on the valve on the propane tank.

⚠ CAUTION If you smell propane, immediately discontinue operation of the heater until the source of the leak has been found and fixed.

3) Set the thermostat to the maximum value

If the temperature is above 80 or 90 degrees, you may not be able to turn the thermostat high enough for the heater to start in the next step. If you wish to continue setting up the heater you will need to chill the thermostat probe.

4) Turn on the heater

The heater will start and, after a few seconds, ignite. The red indicator light near the power switch will turn on until the heater has ignited. You should hear it quietly ignite just after the fan turns on and you will feel the air exiting the heater get warm within a minute. If the heater doesn't ignite after a few minutes (the red indicator light will turn on and stay on), please refer to the troubleshooting guide to help fix the problem.

5) Set the thermostat to the desired temperature.

Your heater is now ready for use.

Normal Operation

1) Check the air inlets and outlets

Check that all the air inlets and outlets are undamaged and unblocked.

2) Check propane supply

Check that the propane tank(s) are securely mounted and contains fuel. Check that the fitting connecting the tank to the gas system is tight. Turn on the valve on the propane tank.



If you smell propane, immediately discontinue operation of the heater until the source of the leak has been found and fixed.

3) Set the thermostat

Set the thermostat to the desired temperature.

4) Turn on the heater

Your heater is now ready for use and will automatically run as necessary to maintain the space at the desired temperature (just like a home furnace.)

5) Turning off the heater

If you need to turn the heater off for the night or the weekend, turn off the heater using the thermostat or the optional remote box. This guarantees that the heater has time to cool down properly.

If you need to turn the heater off for longer than a few days, turn off the heater using the power switch on the side. It is very important that the heater is not running when you shut off the power. If the heater is running, first turn off the heater using the thermostat, wait until the fan has stopped, and then turn off the heater. Turning off the heater with the power switch while it is running is not inherently dangerous, but it will reduce the life of some of the components inside the heater. Once the heater is turned off, close the valve(s) on the propane tank(s).

Service Instruction

Every time you walk by the heater (and at least once a week)

- Check the air inlet and the exhaust outlet for damage or obstructions
- Check the exterior gas lines for damage

Annually before the start of the winter season

- Carefully inspect the propane tank, regulator, and fuel lines for leaks or damage. Replace any damaged components and tighten any loose fittings.
- Clean the air inlet and the exhaust outlet. Remove any debris that has collected during the summer.
- Remove the heater cover. Carefully remove any dust or dirt from the grill and the large fan inside the heater.
- Start up and run the heater for a couple of minutes to check that everything is in working order.
- If you are using a digital thermostat, replace its battery.

Every three years (or when ignition problems occur)

In addition to the annual maintenance,

- Remove the spark probes and check them for damage and deposits. They should not be darker than a light gray or have an excessively rounded tip. If the spark probes are damaged or excessively rounded, they should be replaced. If the spark probe has deposits then carefully remove them with a damp rag or abrasive plastic pad. Illustration 2 below shows the original condition of the spark probe as a reference. When you reinstall the spark probe always use a high temperature antiseize compound rated for at least 1200F on the threads of the mounting screw and, if necessary, seal the joint between the spark probe and the combustion chamber with a high temperature exhaust or furnace cement rated to at least 900F. Be careful to avoid getting any cement on the mounting screw to allow future removal of the spark probe.



Illustration 2: Spark Probe as Originally Installed

Troubleshooting

If this guide doesn't fix your problem please contact the company where you purchased the heater. If you are unable to contact them or you need additional help, please contact Elston Manufacturing at 1-800-845-1385.

⚠ CAUTION For your safety, the propane should always be turned off and the power turned off when troubleshooting this product except when necessary for testing. The heater can start unexpectedly and could pinch or cut fingers, sustain damage from tools, or cause burns from rapidly warming internal surfaces.

What is wrong with the heater?

- A. Heater fails to ignite and fan does not run.
- B. Fan runs but heater fails to ignite.
- C. Heater usually ignites but sometimes does not.
- D. Black smoke from exhaust outlet

A Problem A: Heater fails to ignite and the fan never runs.

Turn down the thermostat and turn off power to the heater using the switch.

Does the green indicator come on when the power is turned on?

No. Check that the heater is receiving power and the positive and ground have not been reversed. If voltage is not detected, do a quick inspection of the electrical system from the heater to the vehicle for obvious problems. If there are no obvious problems, it is recommended that you start at the thermostat and work your way through the components supplying power from the vehicle to the heater until you find the problem. Possible problems include loose connections at terminal bolts, corrosion or mechanical damage to wires, and tripped circuit breakers and blown fuses.

Yes, but just for a moment. There is probably a short inside the heater. Check for loose or damaged wires and connections.

Yes. If you turn up the thermostat all the way does the red light turn on immediately?

No If applicable, check that the thermostat is turned on and set to heat. Check that temperature of the thermostat is set high enough that it will turn on the heater. If the thermostat is a digital model, replace the

batteries. If none of these things work, check that +12 volts DC is coming into the thermostat from the heater and there are no loose connections inside the thermostat.

If the thermostat is working correctly, check that the heater is receiving at least 10VDC. The heater needs at least 11 VDC to function correctly but may fail to function completely below 10 VDC.

Yes The safety system for the heater does not have the correct initial setup. Check that the flap for the sail switch is not stuck in the open position. If the sail switch is not physically stuck open, check that the resistance across the sail switch is above 1 M Ω when the heater is off. If the resistance is below this value, the sail switch needs replacement.

B Problem B: Fan Runs But Heater Fails to Ignite

With the gas off, start the heater by turning up the thermostat to the maximum temperature. The red light should turn on a couple seconds after the fan starts and you should hear a faint clicking noise fifteen to thirty seconds after the blower starts. If you do, then:

Rule out general problems. Carefully check the fuel system. Check that the propane tanks contain fuel, all gas lines are undamaged, and all fittings are tight. Check the connections at the thermostat for problems. Remove the cover of the heater and check the wiring for damage or loose connections and the components in the heater for obvious damage. Check that the heater is getting at least 11.5 VDC.

Inspect the spark ignition system. The spark ignition system should create one spark across the tip of the spark probe in the combustion chamber on each faint click. The spark can be in an incorrect location for any of the following reasons: damage to the spark probe wire, loose connections, and deposits on the spark probe. To access the spark probe to check it for deposits, remove the access panel on the side of the heater by the combustion chamber. The metal tips of the spark probe should only be slightly rounded with an 1/8" gap at the tip. In addition, the insulator on the probe should have no cracks or chips missing and only have light deposits on the insulator. If the spark probe is damaged or excessively round, it should be replaced. If the spark probe only has deposits, carefully remove them with a damp rag or abrasive plastic pad.

The small blower may not be working. With the gas off, check that air is flowing through the combustion chamber and that the small blower is turning. If it is not working, check for loose connections or obstructions or damage to the blower. If you find nothing obvious, remove the blower and test it at 12 VDC to see if it is functioning correctly.

If the red light does not come on and you don't hear the faint clicking noise then

The sail switch or high temperature switch may be malfunctioning. If the sail switch fails to close or the high temperature switch is stuck open the heater will not attempt to ignite. Also loose or damaged wire to either of these items will cause the same problems. Check the wiring to these two items. With the power off to the heater, use a multimeter to check that resistance of the the high temperature switch is less than 1 ohm. If it is higher, it should be replaced. Also, check if the sail switch closes when the heater runs by disconnecting the wiring to the sail switch and checking if the resistance drops to zero when the fan is running. If the wiring and two switches check out ok, refer to the troubleshooting tips above for this problem.

If the red light comes on but you don't hear the faint clicking noise then:

This indicates either a short in high voltage line or a malfunctioning ignition module. Check the high voltage line for damage. If no problems are found, remove the high voltage wire from the spark probe on the combustion chamber (it can be accessed by removing the access panel on the side of the heater by the combustion chamber). With the gas off, double check that no spark is being produced by improvising a 1/8" spark gap from the end of the high voltage terminal to the combustion chamber. If a spark is being produced, remove and inspect the spark probe. Check and fix any possible shorts, adjust the spark gap to 1/8" if necessary, and reinstall the spark probe. If this does not fix the problem refer to the troubleshooting tips at the start of this problem. If no spark is being produced, the spark ignition module needs to be replaced.

C

Problem C: Heater usually ignites but sometimes does not

Check that the propane tank is not low and gas is getting to the heater.

Is any extra ductwork connected to the exhaust or air inlets or outlets?

Yes. The heater should have less than 5 feet connected to the hot air inlet and outlet . Any additional pipe connected to the exhaust should be 1.5-inch or larger pipe less than 8 ft long and have a minimal number of bends. Disconnect all pipe and ductwork from the heater to see if this corrects the problem.

No Carefully check all the inlets and outlets and blower for debris and obstructions. Follow the trouble shooting suggestions for problem B. In addition, use a voltmeter to check if the heater is getting sufficient voltage while it is on. It should be 11.5 to 13.5V for the heater to operate reliably. The heater will operate on 11 to 11.5V but poor ignition and carbon deposits are a possibility.

D Problem D: Black Smoke from Exhaust Outlet

Under normal use, the heater will produce very little, if any, black smoke near the exhaust outlet. A white “smoke” of water vapor is normal during cold weather but darker smoke is often the first sign of a problem with the heater and often shows up first when the vehicle powering the heater is not running. These deposits typically indicate that one of the openings in the heater is obstructed or the heater is not receiving enough voltage while it is running.

Check if the heater is running off of the battery only (ie the vehicle is not running). If the battery is significantly run down or running many accessories, the heater cannot receive enough voltage to operate properly. Running the heater for less time on the battery or starting the vehicle should correct the problem.

If this problem occurs when the vehicle is running or after less than an hour of running on the battery, check the following:

- 1) Check that none of the inlets or outlets to the heater are partially blocked or any ductwork leading to or from the heater is damaged.
- 2) Check that the heater is receiving a voltage of at least 11.5 VDC at the thermostat while the blower is running. A voltage below 11.5 VDC typically indicates a problem in the electrical system between the heater and the vehicle. Start by looking for loose or corroded connections.
- 3) Check that the regulator is producing the correct pressure of 10.5-11 inches water column. A high pressure will cause the heater to receive too much propane.

Installation

⚠ WARNING Improper installation of this heater creates a substantial safety hazard including the risk of property damage, fire, and/or death.

NOTICE Compliance with local regulations is the responsibility of the installer. If you are unsure what local regulations require, please refer to the current regulations in your area or speak with the authority having jurisdiction before beginning installation.

5.1 Overview

The choices you make in installation have huge effects on the safe and reliable operation of this heater. There are four primary issues to focus on:

1. Safe and robust installation of the propane fuel system
2. Safe and robust installation of the electrical system
3. Secure mounting of all parts against long-term vibration
4. Ensuring adequate and consistent air flow to the heater

The purpose of these instructions is to aid you in installing a fully functional heater that is safe and secure under both normal condition and, as much as possible, during an accident. However these instructions are not a substitute for personal knowledge and experience with installing propane and/or electrical systems. Please do not install those areas of the heater unless you have personal knowledge and experience in these areas.

These instructions were written with the latest standards for the US and Canada in mind and are intended to guide you in an installation that meets these standards. At the time of writing, the latest standards were the 2008 edition of NFPA 58, the Liquefied Petroleum Gas Code and the 2005 edition CAN/CSA-B149.5-05, Installation Code for Propane Fuel Systems and Tanks on Highway Vehicles. However, if the regulations that apply in your area conflict with these installation instructions, the local regulations should always be followed instead.

Throughout this guide, the word “must” is used for any instruction that if not followed would create a safety hazard and/or yield an installation that would not comply with current standards. An instruction with the word “should” is necessary either for the proper functioning of the product or improves the long-term safe operation of the product. If you are unable to follow any instructions with the words “must” or “should”, please contact us and/or the authority responsible for regulating or approving your installation to discuss how your installation can be still be completed in a way that is functional, safe, and compliant. Finally, an instruction that recommends indicates an instruction designed to maximize the working life of the product, simplify installation, or improve the appearance of the installed product.

5.2 Unpacking the Heater and Gathering Supplies

Parts Needed for Installation Included with Heater:

- 1 template for mounting holes
- 6 feet self stick rubber seal
- 1 exhaust flange and pair of ring shaped gaskets
- Clips for attaching electrical lines and thermostat probe to the walls
- Hardware for attaching thermostat to the wall

Additional parts required:

- 4 1/4" bolts at least 1/2 inch longer than the thickness of the wall the heater is being mounted on with washers, lock washers, and nuts to match.
- Hardware to attach the exhaust flange
- Length of 18ga stranded wire
- Brackets and clips for attaching fuel lines to the trailer walls
- Propane fuel system including tanks, tank holders, and propane hoses

5.3 Heater placement:

The heater should be located where it is not in the way of normal traffic and, if possible, with enough clearance to remove the cover to the heater and the access panel for the spark probe without unbolting the heater. If you are unable to mount the heater in a position that the on/off switch and indicator lights are easily accessible, a remote box is available as an accessory.

The heater must be mounted in one of the orientations shown below with plenty of room for the air to enter and leave the heater.

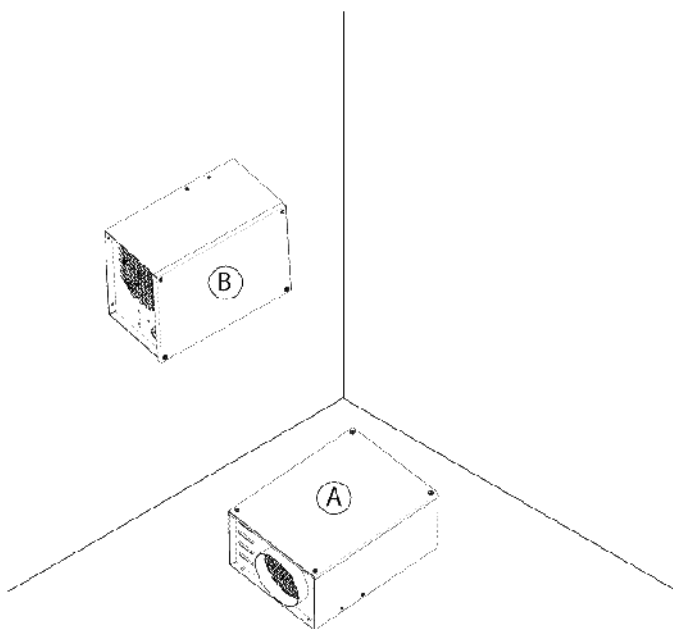

Illustration 3: Mounting Positions

Acceptable Mounting Positions

Position A – Floor Mount

The heater may be installed in any position where the exhaust exits the heater straight down.

Position B – Horizontal Wall Mount

The heater may be mounted on the wall provided it is mounted as pictured (the air inlet is on the left and the air outlet is on the right when facing the cover of the heater).

In order to ensure adequate air flow for the heater to operate properly, the cold air inlet and hot air outlet must be 6" or more from a wall or obstruction. In addition, the sides and top of the heater must have at least 1" of clearance from nearby objects.

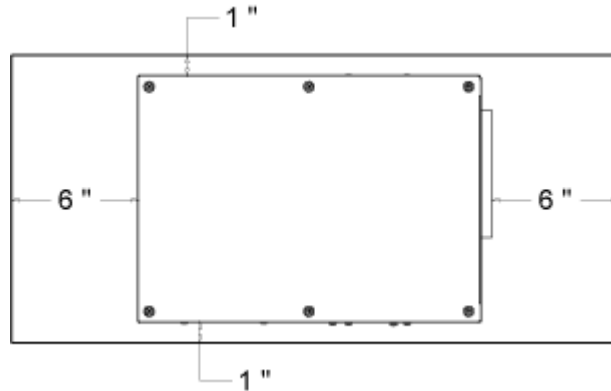

Illustration 4: Mounting Clearances

5.4 Mounting

Check that the template matches the heater. Tape the drilling template in the desired location for the heater, checking that it is level and flat. Center punch the location of the air inlet and outlet holes and one of the top mounting holes indicated on the template. Remove the template and identify the size of the holes on the wall. If you are cutting the larger holes with a jigsaw or saber saw, use a compass to mark the circles.

Drill all three holes to the size indicated on the template.

Lift the heater into place and align it with the mounting holes. Once the heater is lined up, slide a 1/4" bolt (with a washer) into the top mounting hole you drilled. If desired, finger tighten the nuts on this bolt to keep the heater from pulling away from the wall. Level the heater and mark the other three mounting holes. Remove the heater and drill the remaining holes. Lift the heater into place and install and tighten all four mounting bolts

If desired, install the included exhaust coupling to allow redirection of the exhaust or to protect the mounting surface of the heater from damage. An insulating gasket is included for installation between the coupling and the mounting surface for the heater. The coupling fits loosely on the exhaust to allow for slight misalignment of the exhaust pipe and the heater. The small gap between the outside surface of the pipe for the heater exhaust outlet and the inside of the exhaust coupling should be sealed with automotive exhaust sealant or similar compound to ensure an airtight seal.

Mount the thermostat in a location where it may be easily accessed or, if easy access is not desired, on the shell of the heater near the air inlet of the heater. Mount the temperature probe in a location that is shoulder level to the operator. If the thermostat has a remote temperature probe, mount this on a surface that is expected to be the same temperature as what you are heating. In other words, don't mount the probe near the ceiling, the hot air outlet, or on a cold metal surface. If the best mounting surfaces are uninsulated metal surfaces, it is recommended that the probe is mounted with plastic

tinnerman clip or a similar method that will help get the probe closer to the air temperature of the heated area.

5.5 Wiring

The high levels of vibration and the temperature extremes these heaters are exposed to are hard on electrical connections. Always use quality electrical connectors, fittings, and wire as clean, secure connections are essential for both the proper operation of this heater and long-term trouble-free operation.

Run wires from the thermostat to the heater and from the vehicle to the heater. These wires must be secured to the wall of the vehicle and should be stranded wire of at least 18ga. Thinner wires tend to be much less resistant to long-term vibration. Trim the wire so that it can extend at least 6" past the grommet and into the heater.

Check that the power to the heater is off. Connect the wires to the terminal block. Either terminal of the provided thermostat may be connected to either terminal 4 or 6. If another thermostat is used, refer to the instructions provided.

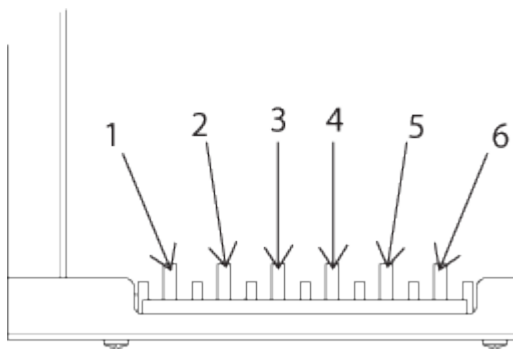

Illustration 5: Terminal Block

Label	Purpose
1	V+ (12V)
2	V- (Ground)
3	V- (Ground)
4	Thermostat Hot
5	Fan
6	Thermostat Heat

Table 1: Wiring Guide For Terminal Block

Fuel System

NOTICE These instructions are intended for general guidance only. Consult the current regulations in your area or the latest standards, NFPA 58 for the United States or CAN/CGA 149.2 for Canada, for exact requirements.

Before you begin mounting any components, it is recommended that you determine the approximate mounting location of all components to ensure that all parts can be connected with the available lengths of hose and tubing. The recommended order of installation is:

- 1) Install the propane tanks or propane tank carriers.
All propane tanks must be "DOT" or "ASME" approved, setup for vapor withdrawal, and mounted in line with the manufacturer's instructions and the applicable code.
Install the propane tank or propane tank carrier, such as the X-1025 or X-1050, following the instructions included with the product. Installation instructions are available for all tanks purchased from Elston Manufacturing. If your tank or tank

carrier does not have instructions, contact the manufacturer for guidance and refer to the installation code that applies in your area.

Any tanks should be mounted at least 18" from any portion of the exhaust system for the heater or the vehicle. If this is not possible, it must be shielded from the exhaust components by a vehicle frame member or a baffle of noncombustible material. The item that is shielding the tank must have an air space between itself and the exhaust component and itself and the tank to properly shield the tank from heat. If a baffle is used, it should be constructed so that it is expected to resist corrosion at least as long as the propane tank.

NOTICE New tanks that are purchased empty come filled with air or an inert gas that needs to be purged before the tanks are filled for the first time. Remember to inform the propane supplier if your empty tank is new.

2) Mount the regulators

All regulators must be CSA/UL approved and securely attached with the vent opening facing straight down. It should be mounted on exterior surface and must not be installed in the space that the heater will be heating. It must be attached so it is supported by screws attached to the mounting holes on the regulator and not by the fittings attached to it. If the regulator is mounted in an unsheltered location, it must have either a durable cover or be installed in an enclosure. If the regulator is mounted at or below the floor level of the vehicle, it must be installed in an enclosure. The enclosure must be

- sufficient size to allow connection to and replacement of the regulator
- vapor tight to the interior of the vehicle
- have 1 square inch or larger vent opening within 1 inch of the bottom of the compartment and 2 inches below the regulator vent opening
- contain no flame or spark producing equipment
- designed and mounted with as much ground clearance as practical

3) Install all hoses and fittings

Attach all fittings to the regulators, heater, and the tanks.

The POL fitting attached to the tank must have a built-in excess flow valve. All fittings including bulkheads must have wrench flat or similar way that each fitting can be individually tightened or loosened (close nipples are not allowed). The threads in fittings must be a tapered pipe thread and sealed with a joint sealant approved for this use.

Attach the hoses as necessary. All hose assemblies must carry a CSA/UL approved label and be 36" or shorter.

4) Install the copper propane line

The copper line should be run as directly as possible between components while maintaining adequate clearance from the exhaust system and areas with a high risk of impact damages such as above the tires. Once the route for the copper tubing is determined, any necessary holes in the frame or floor supports can be drilled and installed with grommets and the tubing can be pulled into place,

trimmed to length, deburred, fitted with the correct nut, flared, and attached. The 3/8" copper line must

- Meet either the specification for either ASTM B 88 (Type K or L) or ASTM B 280. In Canada installations, the tubing must additionally be marked and plastic or rubber coated in accordance with CAN/CSA-B149.5-05.
- Have no joints and can not be extended in any way
- Be protected by grommets or another method with similar protection when traveling through bulkheads or portions of the trailer frame, be securely clamped to the front wall of the trailer, and otherwise supported and secured to minimize the effects of vibration
- Be installed in a protected location that is visible for inspection. It cannot be installed inside the frame or any pipe or tubing.
- Not be installed inside the vehicle except as necessary to hook up to the heater. It should not be closer than 4 inches to any part of the exhaust system, run directly above any tire, or within 6" of any tire.
- Not be in contact with any electrical wiring
- Be connected so that slight shifting and the expansion or contraction that occur with temperature do not cause stress on the fittings

5) Test the System for Leaks

The propane system must be tested for leaks before the operation of the heater is tested or it is placed into operation. This leak test must use a pressure gauge or manometer. If a leak is found, it must be located using a combustible gas indicator, suitable leak detection solution, isolated testing and inspection of piping segments, or a combination of these methods.

Final details

Give the installation one final check to make sure nothing has been forgotten or improperly completed. If everything looks good, the heater is ready to be test fired. For instructions on firing up the heater for the first time please consult the quick start guide. Once the heater has been test fired, the low pressure regulator should be set to deliver 10.5" to 11" W.C. pressure to the heater while it is running.

The installation is now complete and the heater can be placed in service.

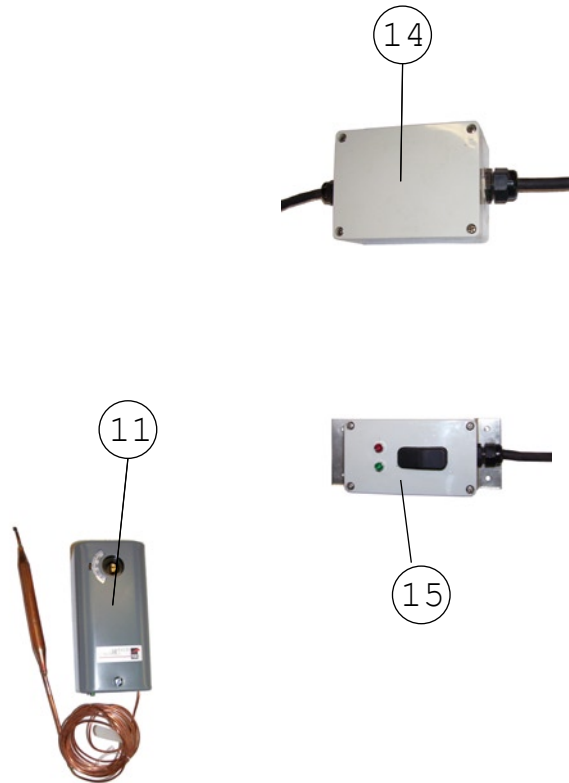
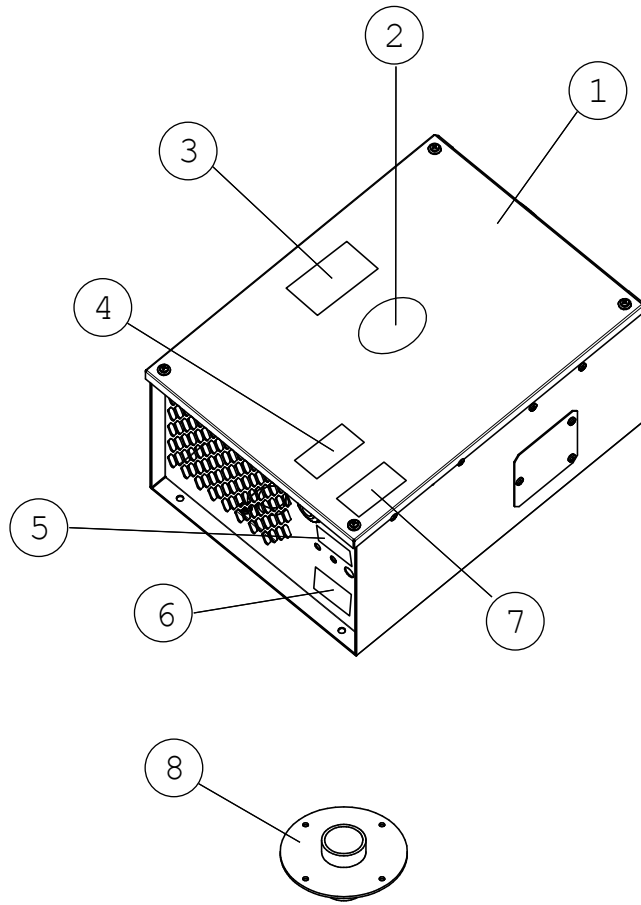

Ref #	Name	Part #	Ref #	Name	Part #
1	Heater Body	see p A2	11	Thermostat w/ Knob (replacement knob HLC-225-01)	HLC-225A
2	Elston Decal	SD-02	12	Owners Manual (not shown)	HD-27
3	Warning - Clearances	HD-52	13	Mounting Template (not shown)	HD-28
4	Attention Installer (removed after install)	HD-48	14	24V Converter Box	HC-500
5	Serial Number	HD-22	15	Remote Box	HC-550
6	Product Specifications	HD-42	1-13	Universal Heater - 12VDC	H-C-1
7	Warning - Product Requirements	HD-23	1-14	Universal Heater - 24VDC	H-C-24V
8	Exhaust Coupling	HC-111	1-13,15	Universal Heater - 12VDC w/ Remote	H-C-1R
9	Gasket for HC-111 (large hole - not shown)	HC-114-01	1-15	Universal Heater - 24VDC w/ Remote	H-C-24VR
10	Gasket for Exhaust (small hole - not shown)	HC-114-02			

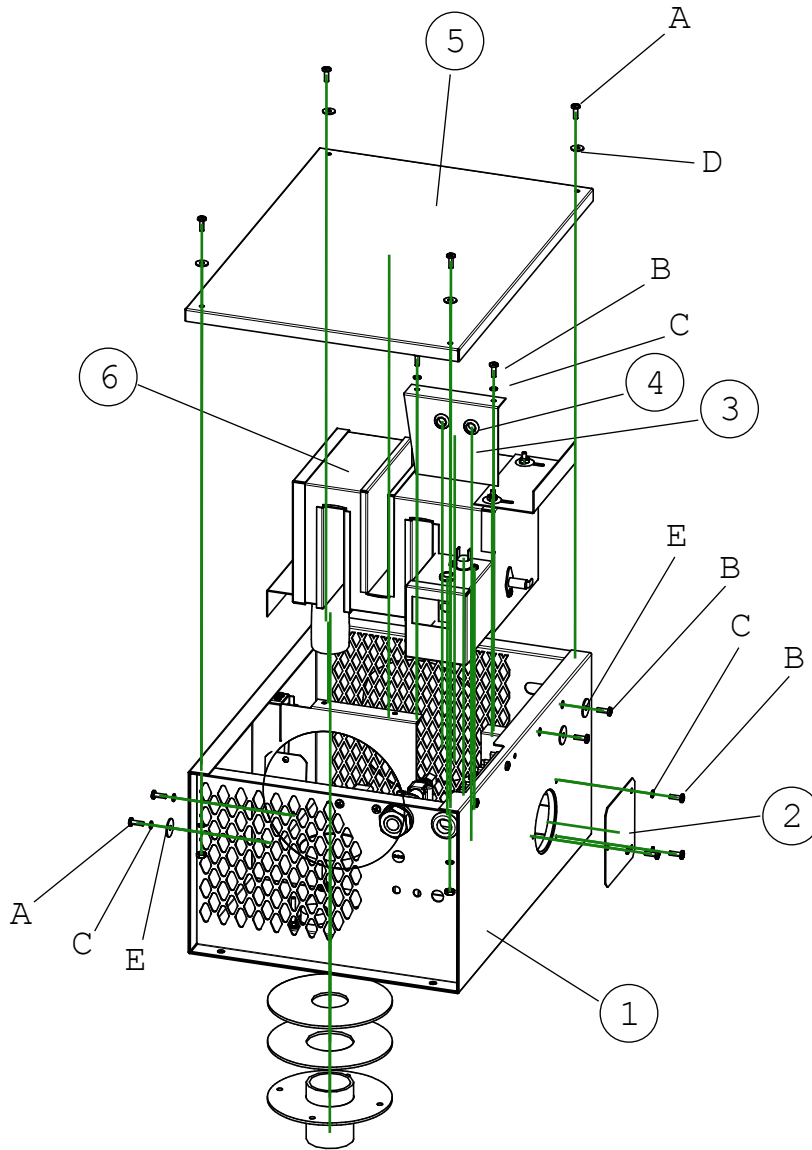

Ref #	Name	Part #	Ref #	Name	Qty
1	Heater Shell	HC-100	A	3/4" #8-32 SS Machine Screw	6
2	Spark Probe Access Panel	HC-1-05	B	1/2" #8-32 SS Machine Screw	7
3	Blower Slot Cover	HC-1-01	C	#8 SS Lock Washer	10
4	3/8" ID Grommet	HLC-407	D	#8 SS Flat Washer	7
5	Heater Shell Cover	HC-101	E	#8 SS Fender Washer	4
6	Combustion Chamber Assembly	see p A4	F	#8-32 SS Hex Nut	3
7	Fan - 6" Diameter	HC-405	G	2 1/2" #8-32 Machine Screw	3
	Mounting Hardware: C,D,F,G (not shown)				

See page A3 for electrical and propane related parts

Use high temperature anti-seize compound on all screws attaching combustion chamber assembly

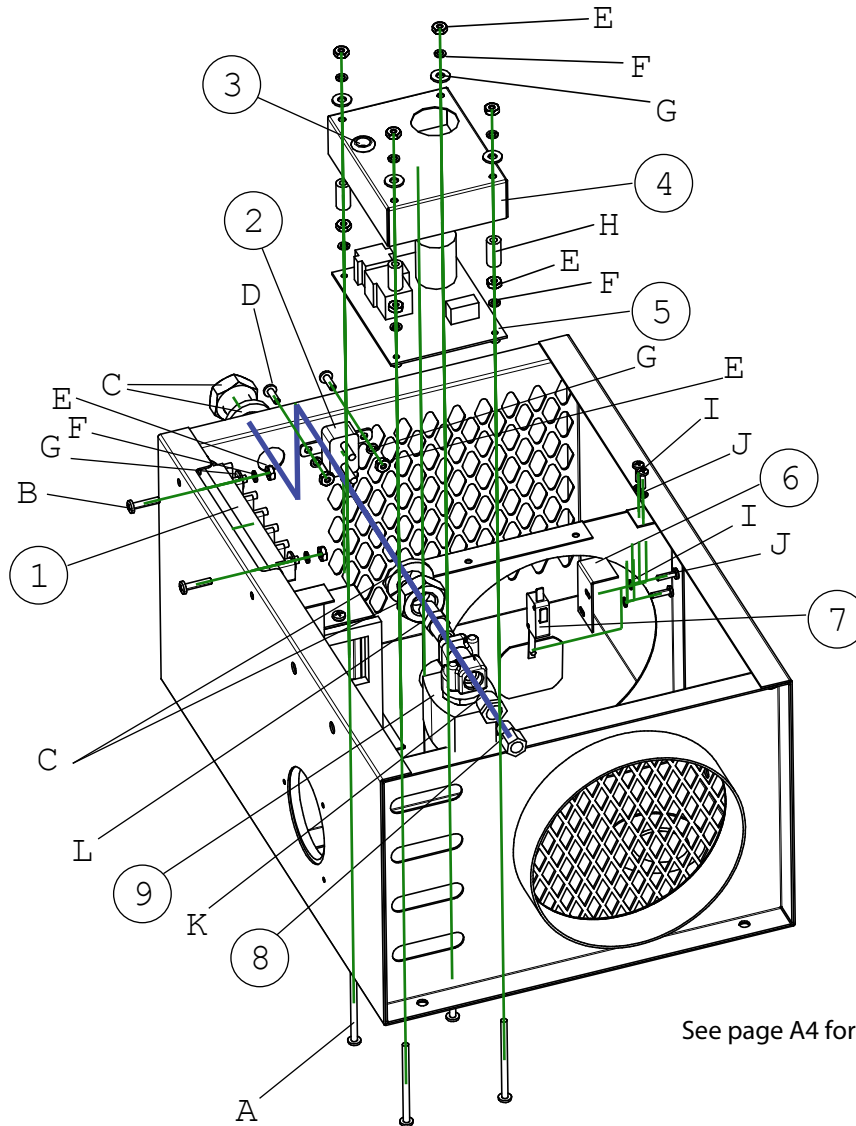

See page A4 for close up of blower inlet area

Ref #	Name	Part #	Ref #	Name	Qty
1	Terminal Block	HC-429	A	1 3/4" #8-32 SS Machine Screw	4
2	Circuit Breaker	HC-409	B	3/4" #8-32 SS Machine Screw	2
3	3/8" ID Grommet	HLC-407	C	Bulkhead Fitting	HLC-218
4	Ignition Module Cover	HC-1-03	D	1/2" #8-32 SS Machine Screw	2
5	Ignition Module w/Relay	HLC-918	E	#8-32 SS Hex Nut	12
6	Sail Switch Mounting Bracket	HC-1-06	F	#8 SS Lock Washer	10
7	Sail Switch	HC-427	G	#8 SS Flat Washer	8
8	Extension Orifice	HC-413	H	3/4" Plastic Standoff - 0.156" ID	4
9	Gas Valve	HLC-229	I	1/2" #6-32 SS Machine Screw	4
10	Green Indicator Light (not shown)	HC-553	J	#6 SS Lock Washer	4
11	Red Indicator Light (not shown)	HC-554	K	1/4" - 1/8" NPT Bushing	1
12	Toggle Switch (not shown)	HLC-401	L	1/4" NPT Hex Nipple	1

Closeup of Blower Area

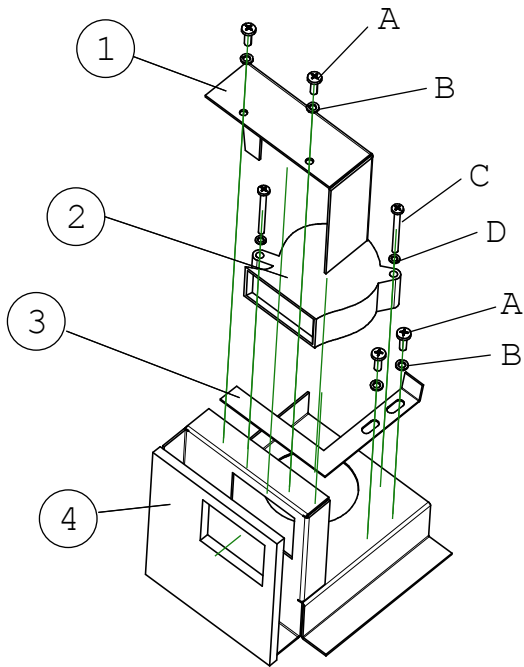

Ref #	Name	Part #
1	Blower Inlet Cover	HC-1-02
2	Small Blower	HC-420
3	Air Adjustment Plate	HC-1-04
4	Combustion Chamber Inlet Gasket	HC-1-07

Ref #	Description	Qty
A	1/2" #8-32 SS Machine Screw	5
B	#8 SS Lock Washer	7
C	1 1/2" #8-32 SS Machine Screw	2
D	#6 SS Lock Washer	2

Combustion Chamber Assembly

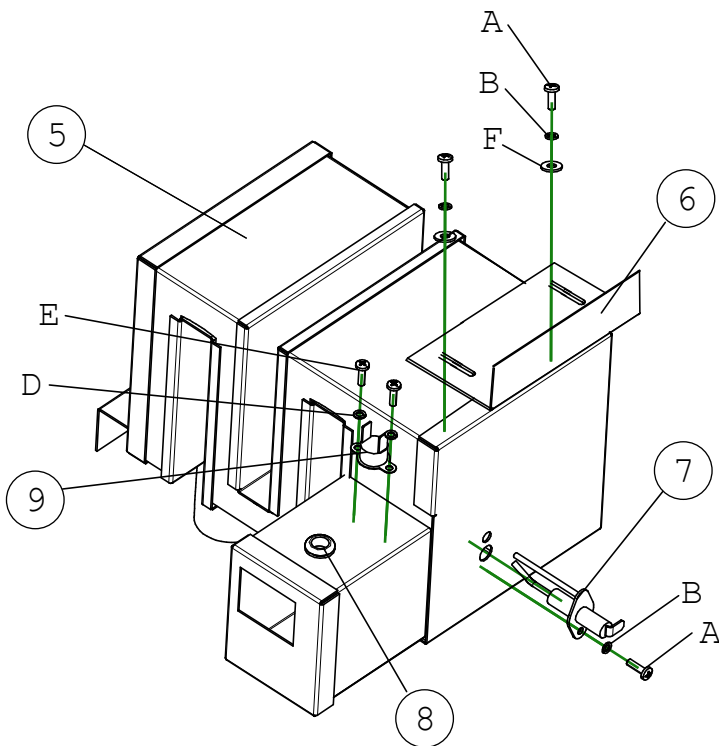

Ref #	Name	Part #
5	Combustion Chamber	HC-200
6	Comb. Chamber Top Mounting Bracket	HC-107
7	HC Spark Probe	HC-416
8	3/8" ID Gasket	HLC-407
9	High Limit Switch	HC-414
5,7-9, D,E	Combustion Chamber Complete	HC-200C
10	High Voltage Cable (not pictured)	HC-422

Ref #	Description	Qty
E	1/2" #6-32 SS Machine Screw	2
F	#8 SS Fender Washer	2

Use high temperature anti-seize compound on all screws in combustion chamber assembly

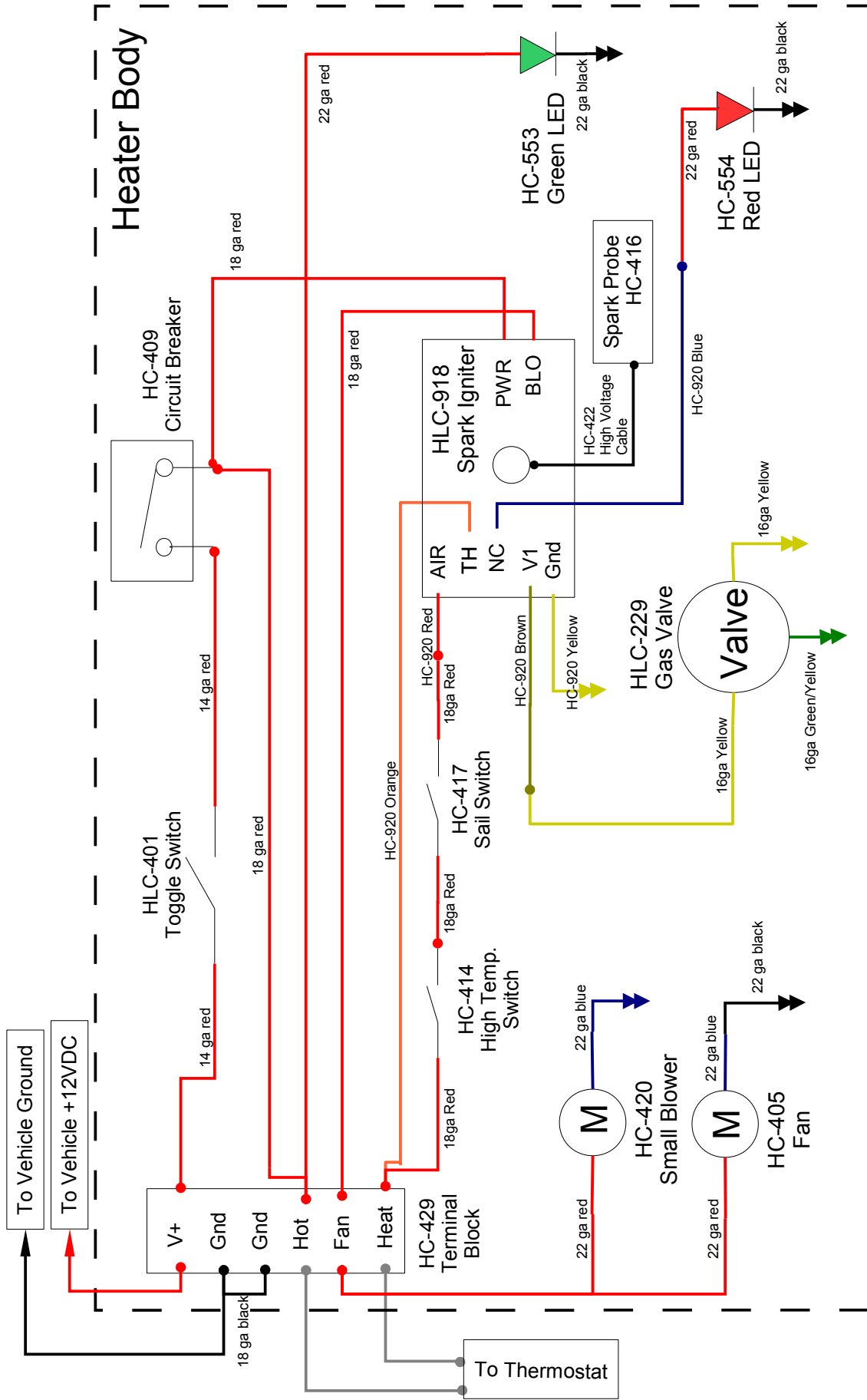

Unit Wiring Diagram
Revision 5a
3/2012

- Field Serviceable Connection (terminal or quick connect)
- Connected to Ground Terminal on HC-429

Installation of the HC-550 Remote Box



CAUTION Improper installation of this accessory will prevent the heater from operating and may damage the heater. Always have gas and power off to the heater throughout the installation process and until it is time for final testing.

Overview

The purpose of these instructions is to aid you in installing a HC-550 remote box on a H-C-1 (12V) or H-C-24 (24V) universal heater that uses a 6 terminal block. For older versions of the heater that use a 4 terminal wiring block, refer to revision a of the HC-550 installation instructions or revision f of the HC owners manual for the correct instructions.

As with the installation of the heater itself, the choices you make in installation have huge effects on the safe and reliable operation of this heater. The high levels of vibration and the temperature extremes these heaters see are hard on electrical connections. Always use quality electrical connectors, fittings, and wire, as clean, secure connections are essential for the long-term trouble-free operation of this heater.

Unpacking the Remote Box and Gathering Supplies

Parts Needed for Installation Included with Heater:

- 1 HC-550 remote box with 6' 18-4 cord attached
- 1 parts bag with
 - (3) #10 ring terminals
 - (1) 1/4" fully insulated push on terminal
 - (6) #8 sheet metal screws w/ 4 #8 flat washers
 - (4) clamps for 18-4 cord

Additional parts required:

- 6 #8 screws appropriate for attaching remote box and clamps to wall if included sheet metal screws will not work

Mounting Remote Box

Mount the remote box in a position where the switch can be easily accessed, the lights are visible, and the attached cord will extend at least 6" into the wiring grommet on the side of the H-C heater when properly secured. The preferred orientation of the box is with the switch on the left but the box can be mounted in any position if required. Once the mounting position is determined, remove the cover to the remote box and mark the

location of the two mounting holes on the wall. Drill pilot holes if necessary and screw the box to the wall with the #8 screws. Reinstall the cover to the remote box.

Wiring

Please see appendix B of the HC owners manual for the wiring diagram of the heater with and without the HC-550 remote box.

Before beginning the wiring, make sure that power is off to the heater. Remove the cover to the H-C heater. Trim the cord running from the remote box so that it extends 6” into the heater when it runs through the wiring grommet. Strip off the outer black insulation on the cord so that it extends only 1” into the heater shell. Trim the black wire so that it extends 4” into the heater shell and the other three wires so that they extend 6” into the heater shell. Strip 5/16” of insulation from the end of each wire and install #10 rings on the white, black, and red wires and the 1/4” female terminal on the green wire.

Remove the red 18ga jumper wire between terminal #4 on the terminal block and the circuit breaker. Verify that the 18ga red wire from the PWR terminal on the HLC-918 ignition module is connected to the bottom terminal of the circuit breaker. Separate the blue wire from the control board and the red wire to the red indicator at the quick connects. The heater will differ slightly from the wiring diagram for the H-C heater with HC-550 remote box shown in appendix B when not factory installed. Both of these difference are minor and will not affect the operation of the heater. The green indicator on the heater will still be installed in the heater and working correctly while the red indicator will no longer be connected. It is recommended that you either label the red indicator as non-functional, remove the red indicator from the heater, or splice the red indicator into the green wire running to the remote box.

Connect the green wire to the blue wire from the control board. Connect the white wire to the bottom terminal on the circuit breaker. Connect the red wire to the #4 (Thermostat hot) stud on the terminal block. Connect the black wire to the #2 or #3 (ground) stud on the terminal block. See illustration 1 and table 1 for more information. The HC-550 is now wired to the heater.

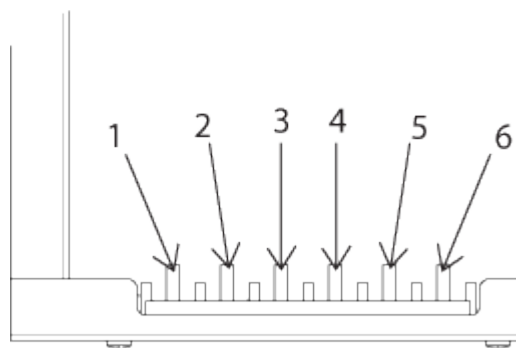

Illustration 1: Terminal Block

Label	Purpose
1	V+ (12V)
2	V- (Ground)
3	V- (Ground)
4	Thermostat Hot
5	Fan
6	Thermostat Heat

Table 1: Wiring Guide For Terminal Block

Testing

Give the installation one final check to make sure nothing has been forgotten or improperly completed. Check that all gas fittings remain tight. If everything looks good, turn off the switch on the remote box and turn the thermostat all the way up. Turn on power to the heater, turn the gas on to the heater, and turn on the switch on the side of the heater. Nothing should happen except the green light on the side of the heater will come on. Next turn on the switch on the remote box. The fans on the heater should start and the green light on the remote box should come on. After a few seconds the red light will illuminate and, after a couple of minutes, the heater will light. Once the heater lights, the red light will go out. Once the heater has lit, turn off the switch on the remote box. The heater should immediately go out, the green light will go dark, and the the heater will start its cool down cycle (you will not hear any additional sparking.) After 3 or 4 minutes, the fans will stop. Once the heater has passed this testing with no problems, the heater can be placed in service.

LIMITED WARRANTY TERMS

Elston Manufacturing, Inc. offers a one (1) year, non-transferable, Limited Warranty against specified defects as set forth below for Elston Manufacturing, Inc. product lines from the date of purchase through proof of purchase by providing original receipt.

This Limited Warranty specifically excludes normal wear and tear of products and is provided solely under the conditions that the product has been properly installed, operated and maintained in accordance with all applicable instructions. Proper installation instructions, or operating manuals, are provided with each product and operating condition. Travel, diagnostic cost, labor, transportation and any and all such costs related to repairing a defective product will be the responsibility of the owner. This warranty is extended only to the original owner of any equipment, the end user.

Elston Manufacturing, Inc.'s sole obligation under this Limited Warranty is to, in its sole and absolute discretion, either repair, modify, or replace (i.e. correct), Elston Manufacturing, Inc.'s products subject to this Limited Warranty. The allegedly defective products must be returned to Elston Manufacturing Inc. or an authorized service center freight paid by buyer. After confirmation by Elston Manufacturing, Inc. that a defect does exist in the product that is covered under this Limited Warranty then Elston Manufacturing, Inc. shall, in its sole and absolute discretion, either repair, modify or replace the product(s) and return the product(s) to the owner freight paid by Elston Manufacturing, Inc.

Elston Manufacturing, Inc. products received by Elston Manufacturing, Inc. within one (1) year from the original sale date to customer and found to be defective as referenced above will be corrected as referenced in the previous paragraph at no charge for parts (provided by original factory) or labor but will include freight paid by buyer. Failure to use original factory parts voids this warranty. Elston Manufacturing, Inc. products received by Elston Manufacturing, Inc. after one (1) year from original shipment date to customer will be corrected as foresaid for a charge of the then-current sale price of parts and labor with freight paid by buyer. Exception: Any parts to be found defective at any time that come under a recall status from providing manufacturer, will be covered under the terms and conditions of the recall status provided by manufacturer.

THIS LIMITED WARRANTY BY ELSTON MANUFACTURING, INC. IS IN LIEU OF ANY AND ALL OTHER WARRANTIES, EXPRESSED OR IMPLIED, INCLUDING WITHOUT LIMITATION TOTHE IMPLIED WARRANTIES OF MERCHANTABILITY AND FITNESS FOR A PARTICULAR PURPOSE. NO ONE IS AUTHORIZED BY ELSTON MANUFACTURING, INC. TO EXTEND OR ALTER THE TERMS OF THIS LIMITED WARRANTY. ELSTON MANUFACTURING, INC. ASSUMES NO LIABILITY FOR LOSS OF USE OR ANY DIRECT, INDIRECT, INCIDENTAL, SPECIAL, CONSEQUENTIAL OR OTHER DAMAGES OF ANY KIND IN RESPECT TO THE USE OF THE ELSTON MANUFACTURING, INC EQUIPMENT.

Accessory items furnished by Elston Manufacturing, Inc. are covered by a Limited Warranty for a period of one (1) year from date of original sale, subject to the conditions, limitations, and disclaimers stated above, for replacement of defective materials, provided such items are returned freight paid by buyer to Elston Manufacturing, Inc. and are determined by Elston Manufacturing, Inc. to be defective in its sole and absolute discretion.

This Limited Warranty shall not apply to any piece of equipment, parts or accessories repaired by anyone other than Elston Manufacturing, Inc. personnel, or its authorized service organizations.



ELSTON MANUFACTURING INC.
706 N Weber
Sioux Falls, SD 57103
www.elstonmfg.com 1-800-845-1385