

Elston Manufacturing Series 32A Installation Guide

Installation Instructions

for the Series 32A Laydown Tank

Thank you for purchasing a Series 32A laydown tank from Elston manufacturing. This tank is a 100lb capacity vapor withdrawal propane tank suitable for mounting on vehicles in the US and Canada.

Overview:

The purpose of these instructions is to aid you in installing a fully functional propane container or container holder that is safe and secure under both normal condition and, as much as possible, during an accident and that maximizes the useful life of this device. These instructions were also written with the latest standards for the US and Canada in mind and are intended to guide you in an installation that meets these standards. At the time of writing, the latest standards were the 2008 edition of NFPA 58, the Liquefied Petroleum Gas Code and the 2005 edition CAN/CSA-B149.5-05, Installation Code for Propane Fuel Systems and Tanks on Highway Vehicles. However, if the regulations that apply in your area should conflict with these installation instructions the regulations should always be followed instead.

Throughout this guide, the word “must” is used for any instruction that if not followed would create a safety hazard and/or yield an installation that would not comply with current standards. An instruction with the word “should” is necessary either for the proper functioning of the product or improves the long-term safe operation of the product. If you are unable to follow any instructions with the words “must” or “should”, please contact us and/or the authority responsible for regulating or approving your installation to discuss how your installation can be still be completed in a way that is functional, safe, and compliant. Finally, an instruction that recommends indicates an instruction designed to maximize the working life of the product, simplify installation, or improve the appearance of the installed product.

General Mounting Location of Tank:

The tank must be mounted where the possibility of damage during both normal operation and accidents is minimized while still insuring easy accessibility to turn on and off the flow of propane at the tank and to refill it when necessary. This location varies depending on whether the tank is mounted on a semi-trailer or the cargo portion of a truck body and is summarized in illustration 1.

- **Semi trailer**
For a typical semi trailer, the tank must¹ be mounted between the trailer legs and the forward most of the rear axles. The recommended location is between one-third and one-half of the way back from the trailer legs to the forward most of the rear axles. This location maximizes the distance between the tank and the tires to attempt to minimize impacts from stones and other debris and avoid the worst of the road spray in order to minimize the increased corrosion they cause.
- **Truck body**
On the typical truck body, the tank must² be mounted between the front and rear sets of axles under the cargo area of the truck. The recommended location is approximately halfway between

¹ As a result of safety issues and due to the geometry of the tank, all other locations are essentially eliminated.

² See footnote 1 above.

the sets of axles. As for the semi trailer, this location attempts to minimize the increased corrosion due to close mounting to the wheels.

The container should be mounted at least 18” from any portion of the exhaust system. If this is not possible and the container or the container holder must be installed within 18” of the exhaust system, it must be shielded from the exhaust component by vehicle frame member or a baffle of noncombustible material. The item that is shielding the tank must have an air space between it and the exhaust component and it and the tank to properly shield the tank from heat. If a baffle is used, it should be constructed so that it is expected to resist corrosion at least as long as the tank.

If the tank cannot be installed in the recommended location for the type of vehicle it is mounted on, it should be mounted at least 3 feet from all wheels and axles. If the tanks are mounted closer than recommended to the front of the vehicle or mounted on a truck body, especially if it will be used in areas that use lots of road salt and have significant amounts of stones (and other debris) to impact the tank, a baffle can be mounted forward of the tank. This baffle will extend the service life of the tank.

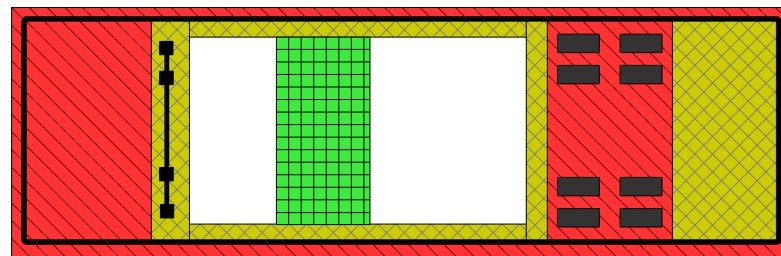

Semi-trailer (bottom view)

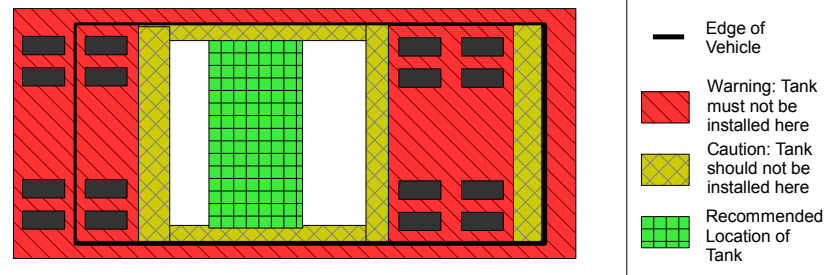

Cargo Area of Truck Body (bottom view)

Illustration 1: Installation Location of Tank

Illustration 1 summarizes the installation location given in the section above. Note that green region is recommended but both the green and white area are acceptable.

Refining the Mounting Position of Tank

The tank must be mounted with the mounting brackets on the tank facing up and as indicated by the decals on the tank. Failure to do so will certainly cause the appliance connect to this tank to not work correctly and is a significant safety hazard.

The end of the tank with the valve and controls must face one of the sides of the trailer and the front of the guard should be set back at least 12” from the outside edge of the trailer. In addition, no part of the tank should be within 12” of the sides of the trailer and no part of the tank and the attached parts must never extend beyond a line between the side of the trailer and the bottom of the outside tire at the minimum height of the suspension.

Checking Ground Clearance

In order to protect the tank from accidental damage, it should be mounted as directly as possible to the supports for the floor of the trailer or truck body to ensure as much ground clearance as practical. The bottom of the tank when mounted (see illustration 2 below for tank dimensions) must be above the bottom of one or more of the following substantial components on the vehicle: a structural component of the body, a structural component of the frame or subframe, the engine, or the transmission (including the housings of other transmission related components mounted directly to the frame). In other words, when the vehicle is traveling down the road there must be a substantial part of the vehicle that will contact debris on the road before that debris is able to contact the tank. When checking this clearance, remember to consider it for both an empty and a fully loaded vehicle.

Mounting the Tank

The tank must be installed so that remains securely mounted under both the vibration of normal use and the large forces present during an accident. In addition, the materials used for mounting must be suitable for use under the corrosive conditions present under the vehicle.

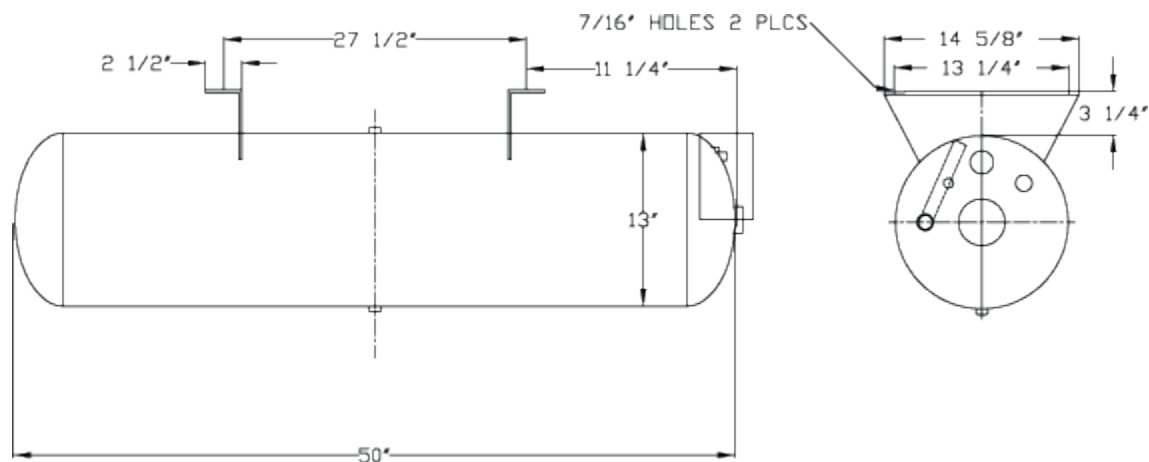

Illustration 2: Dimensions of Tank

The tank can be mounted directly to the floor supports if it can be attached in line with the recommendations of the trailer manufacturer. If the existing holes shown in illustration 2 do not line up with the supports, additional holes may be drilled in the mounting bracket. The tank should be mounted to supports as far apart as possible as long as any holes added are not be within 1 1/2" on center of an existing hole and are the same distance from the edge of the flange as the existing holes. However, manufactures of most trailers and bodies that use C-channel or I-beams to support the floor do not recommend drilling through the flange (due to a high risk of fatigue failure of the drilled support). In this case, you will either need the mounting kit for this tank (available from Elston) or need to build your own brackets to attach the tank.

If you wish to build your own brackets they must be able to withstand a load equal to four times the weight of the fully loaded tank in any direction without permanently deforming. It is recommended that these brackets require no welding or drilling to the bracket on the propane tank. However, welding and drilling is allowed but must be limited to the mounting bracket and must not measurably weaken the mounting bracket. As a result, if a hole is added to the flange, it must not be within 1 1/2" of an existing hole and should be the same distance from the edge of the flange as the existing hole.

Installing the Tank

Warning: Improper installation of this propane container creates a substantial safety hazard including the risk of property damage, fire, death.

Attention: Current regulations in your area may require that the installer of this container meet certain requirements and/or that the completed installation be inspected. If you are unsure what is required, please refer to the current regulations in your area or speak with the authority having jurisdiction before beginning installation to confirm that the installer meets the requirements and the completed installation is properly inspected if required.

- 1) If you have not already done so read the previous sections of the installation guide.
- 2) Determine and mark the approximate mounting location for the tank. Refer to the sections on “General Mounting Location for Tank” and “Refining Mounting Position of Tank” for the recommendations and restrictions on the mounting location of the tank.
- 3) If you did not already do so, determine if the tank can be mounted directly to the trailer or vehicle or if additional brackets are required.
- 4) Verify that the clearance for the tank exceeds the minimum allowable clearance. Do not forget to include any reduction in clearance caused by mounting, including the brackets. Do not mount the tank with insufficient clearance as this creates a substantial safety hazard.
- 5) If mounting the tank directly to the trailer or vehicle, mark the 4 7/16” holes attaching the tank to the frame. If this requires that additional holes be drilled in the mounting bracket of the tank, these holes must as far apart as possible to minimize stress on the mounting bolts and bracket as long as any holes added are not be within 1 1/2” on center of an existing hole or 3/4” of a bend or edge. Drill the holes in the frame and tank and treat any newly exposed metal with a rust resistant coating such as a rust resistant enamel. Attach the bolt to the frame with at a zinc plated grade 5 bolts and matching hardware or, for better corrosion resistance, stainless steel hardware with similar strength. It is recommended that washers be used on both surfaces to protect the finish from damage.
- 6) If mounting the tank with the Elston mounting kit follow the instructions included with the kit.
- 7) If mounting the tank with brackets you fabricated yourself, install the mounting brackets and attach the tank to the mounting brackets with 4 7/16” grade 5 or equivalent bolts.

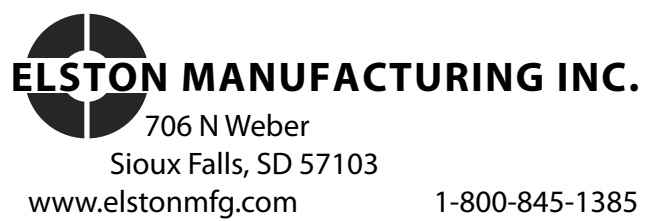

ELSTON MANUFACTURING INC.

706 N Weber

Sioux Falls, SD 57103

www.elstonmfg.com

1-800-845-1385